

Installation Manual **DOPPLER SONAR**

Model **CI-68**

(Product Name: DOPPLER SONAR CURRENT INDICATOR)

SAFETY INSTRUCTIONS	i
SYSTEM CONFIGURATIONS.....	iii
EQUIPMENT LISTS.....	iv
1. INSTALLATION OVERVIEW	1-1
1.1 Selection of Installation Site for Transducer	1-1
1.2 Ground	1-3
1.3 Changing Power Supply Voltage	1-5
2. MOUNTING.....	2-1
2.1 Monitor Unit/Control Unit.....	2-1
2.2 Transceiver Unit.....	2-7
2.3 Junction Box (option)	2-8
2.4 Transducer (Hull Unit).....	2-8
2.5 DC/AC Inverter.....	2-12
3. WIRING.....	3-1
3.1 Wiring the Control Unit.....	3-1
3.2 Wiring the Transceiver Unit.....	3-2
3.3 Connecting the Junction Box	3-4
3.4 External Equipment.....	3-6
3.5 DC/AC Inverter.....	3-8
4. ADJUSTMENTS	4-1
4.1 [INSTALLATION] menu	4-1
4.2 Input/Output Data.....	4-8
4.3 External Noise and Interference Check	4-9
4.4 Setting Output Data	4-12
4.5 DIP Switch Setting	4-13
4.6 Sea Trial Check	4-14
PACKING LISTS	A-1
OUTLINE DRAWINGS	D-1
INTERCONNECTION DIAGRAM	S-1



FURUNO ELECTRIC CO., LTD.

www.furuno.com

All brand and product names are trademarks, registered trademarks or service marks of their respective holders.

ECF

(Elemental Chlorine Free)

The paper used in this manual
is elemental chlorine free.

FURUNO ELECTRIC CO., LTD.

9-52 Ashihara-cho,
Nishinomiya, 662-8580, JAPAN

• FURUNO Authorized Distributor/Dealer

All rights reserved. Printed in Japan

Pub. No. IME-72520-E

(TASU) CI-68

A : NOV. 2003

E : NOV. 14, 2017





0 0 0 1 4 8 0 2 4 1 4











SAFETY INSTRUCTIONS





Read these safety instructions before you operate the equipment.





 WARNING	Indicates a condition that can cause death or serious injury if not avoided.
 CAUTION	Indicates a condition that can cause minor or moderate injury if not avoided.

 Warning, Caution	 Prohibitive Action	 Mandatory Action
--	--	--

 WARNING	
	Turn off the power at the switchboard before beginning the installation. Fire or electrical shock can result if the power is left on.
	Do not install the display unit or transceiver unit where it may get wet from rain or water splash. Water in the equipment can result in fire, electrical shock or damage the equipment.
	Do not open the cover unless totally familiar with electrical circuits and service manual. High voltage exists inside the equipment, and a residual charge remains in capacitors several minutes after the power is turned off. Improper handling can result in electrical shock.
	The transceiver unit weights 17 kg. Reinforce the mounting area, if necessary.

 WARNING	
	Install the specified transducer tank in accordance with the installation instructions. If a different tank is to be installed the shipyard is solely responsible for its installation, and it should be installed so the tank doesn't strike an object. The tank or hull may be damaged if the tank strikes an object.
	The mounting location must be away from rain and water splash.
	Use the proper fuse. Use of a wrong fuse can result in damage to the equipment or cause fire.

 CAUTION	
	<p>Be sure that the power supply is compatible with the voltage rating of the equipment.</p> <p>Connection of an incorrect power supply can cause fire or damage the equipment.</p>
	<p>Do not install the transducer where noise or air bubbles is present.</p> <p>Performance will be affected.</p>
	<p>Do not allow warm water or any other liquid other than seawater or fresh-water to contact the transducer.</p> <p>Damage to the transducer may result.</p>
	<p>Power on the transducer in the water.</p>

 CAUTION													
	<p>The transducer cable must be handled carefully, following the guidelines below. Keep fuels and oils away from the cable. Locate the cable where it will not be damaged.</p>												
	<p>Ground the equipment to prevent electrical shock and mutual interference.</p>												
	<p>Observe the following compass safe distances to prevent interference to a magnetic compass:</p> <table border="1" data-bbox="810 775 1362 976"> <thead> <tr> <th></th> <th>Standard compass</th> <th>Steering compass</th> </tr> </thead> <tbody> <tr> <td>Transceiver unit</td> <td>2.00m</td> <td>1.30m</td> </tr> <tr> <td>Control unit</td> <td>0.30m</td> <td>0.30m</td> </tr> <tr> <td>Monitor unit</td> <td>0.80m</td> <td>0.55m</td> </tr> </tbody> </table>		Standard compass	Steering compass	Transceiver unit	2.00m	1.30m	Control unit	0.30m	0.30m	Monitor unit	0.80m	0.55m
	Standard compass	Steering compass											
Transceiver unit	2.00m	1.30m											
Control unit	0.30m	0.30m											
Monitor unit	0.80m	0.55m											

SYSTEM CONFIGURATIONS

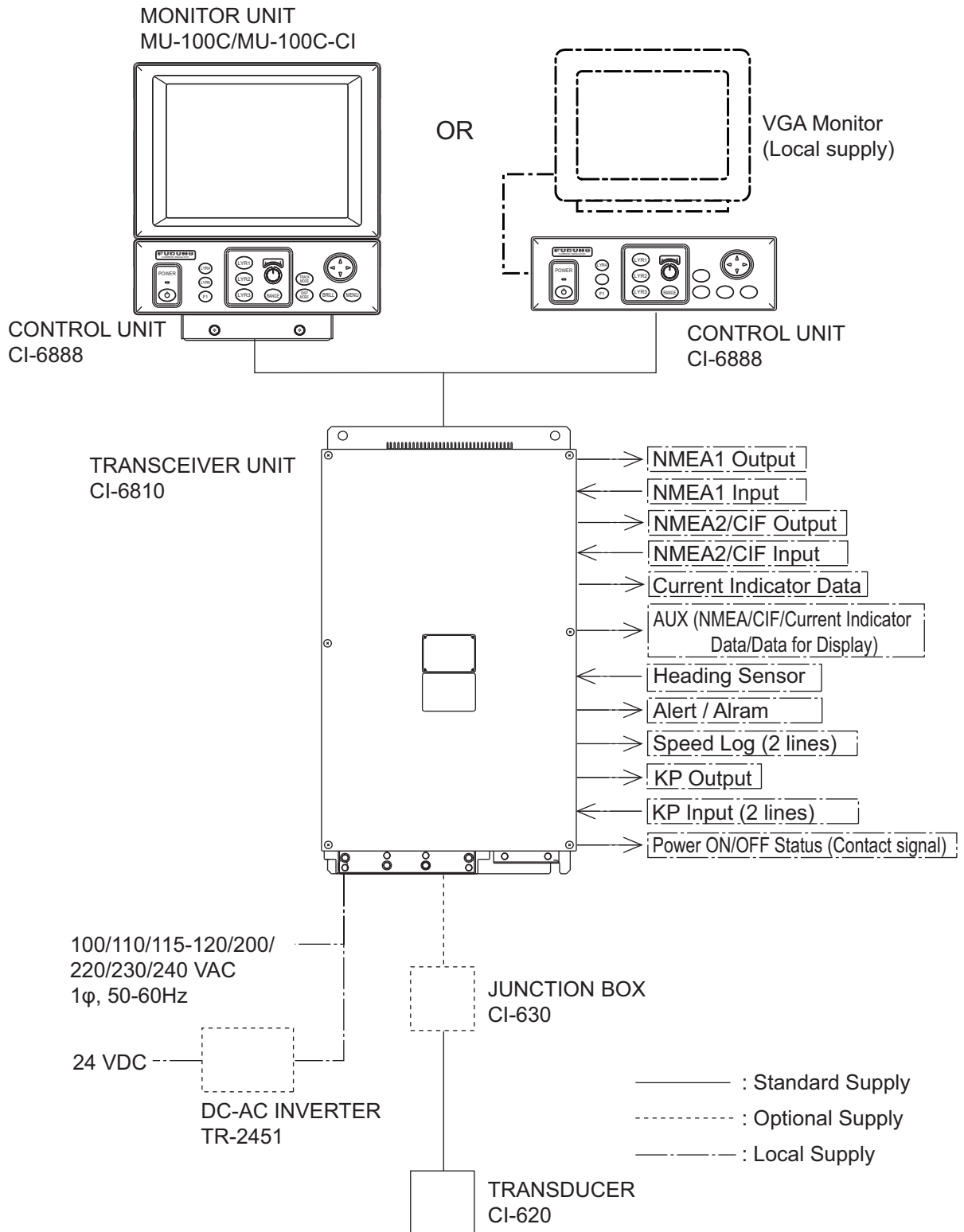

EQUIPMENT LISTS

Standard Supply

Name	Type	Code No.	Qty	Remarks	
Control/Monitor Unit	CI-6888/MU-100C-CI	-	1 set	w/display unit	
	CI-6888/MU-100C	-			
Control Unit	CI-6888	-		no display unit	
Transceiver Unit	CI-6810	-	1		
Transducer	CI-620-1-68	-	1 set	w/10 m cable	Select one.
	CI-620-2-68	-		w/20 m cable	
Transducer Casing	CI-620-T-F	-	1		
Thru-Hull Pipe	CI-620-K-F	-	1		
Installation Materials	CP66-01600	000-070-017	Choose one.	Between transceiver and control units	10 m
	CP66-01610	000-070-018			20 m
	CP66-01620	000-070-019			30 m
	CP66-01630	000-070-020			50 m
	CP66-01501	006-917-660	1	For transducer unit	
	CP66-01504	006-917-350	1	For transceiver unit	
	CP66-01503	006-916-750	1	For display unit	
Accessories	FP02-05100	000-012-474	1	FP06-01102, FP02-05101	
Spare Parts	SP66-00801	006-916-730	1	For control unit	
	SP66-00800	000-070-002	1	For control/monitor unit, w/SP06-01101, SP66-00801	
	SP66-00802	006-917-330	1	For 100 VAC	For transceiver unit
	SP66-00803	006-917-340		For 200 VAC	

Optional Supply

Name	Type	Code No.	Qty	Remarks	
Junction Box	CI-630	-	1 set	w/CP66-02201	
Cable (4P)	Z-6FVNV-SX-C 3P+1P	000-146-086	Choose one.	For junction box	5 m
		000-146-087			10 m
		000-146-088			15 m
		000-146-089			20 m
		000-146-090			30 m
Cable Assembly	66S1239*5M*	000-148-493-10	1	Between display unit and control unit	
	66S1239*10M*	000-148-498-10			
Accessories	FP06-01120	006-556-260	1 set	For fixing control unit, Box type	
	FP66-00601	006-916-680		For fixing control unit, V-type	
Transducer Casing	CI-620-T-S	-	1 set	For steel ship	
Thru-Hull Pipe	CI-620-K-S	-	1 set	For steel ship	
DC-AC Inverter	TR-2451	-	1 set		
Multi-Purpose LCD Display	MU-100C-CI	-	1 set		
	MU-100C	-	1 set		
Control unit flush mount kit	OP06-18	006-556-320	1		

This page is intentionally left blank.

1. INSTALLATION OVERVIEW

The Doppler Sonar Current Indicator CI-68 consists of a monitor unit (not supplied with black box type), control unit, transceiver unit, junction box and transducer (hull unit). To obtain absolute tide even in deep waters, the CI-68 must be supplied with the speed/course data (or position data) from navigation equipment (GPS) and heading data from a gyrocompass (via an A-D converter). The equipment can output ship's speed and true bearing data to a radar or scanning sonar for true-motion display. Further, current data can be output to an echo sounder or scanning sonar in CIF format.

To obtain full performance from the equipment, the installation of the units, especially the hull unit, is very important. Poor siting of units or poor cable layout may cause pick-up of noise, or give interference to other units. This chapter presents an overview of how to install the equipment.

1.1 Selection of Installation Site for Transducer

Transducer (Hull tank)

The performance of the equipment largely depends on the installation of the transducer unit, and a very important consideration is the installation site. It should meet the following requirements.

- a) No projections (such as sonar's retraction tank) should exist in the hatched area shown below. However, when the transducer projects below the lowest part of the keel, the effects when the sonar transducer is lowered must be taken into account.

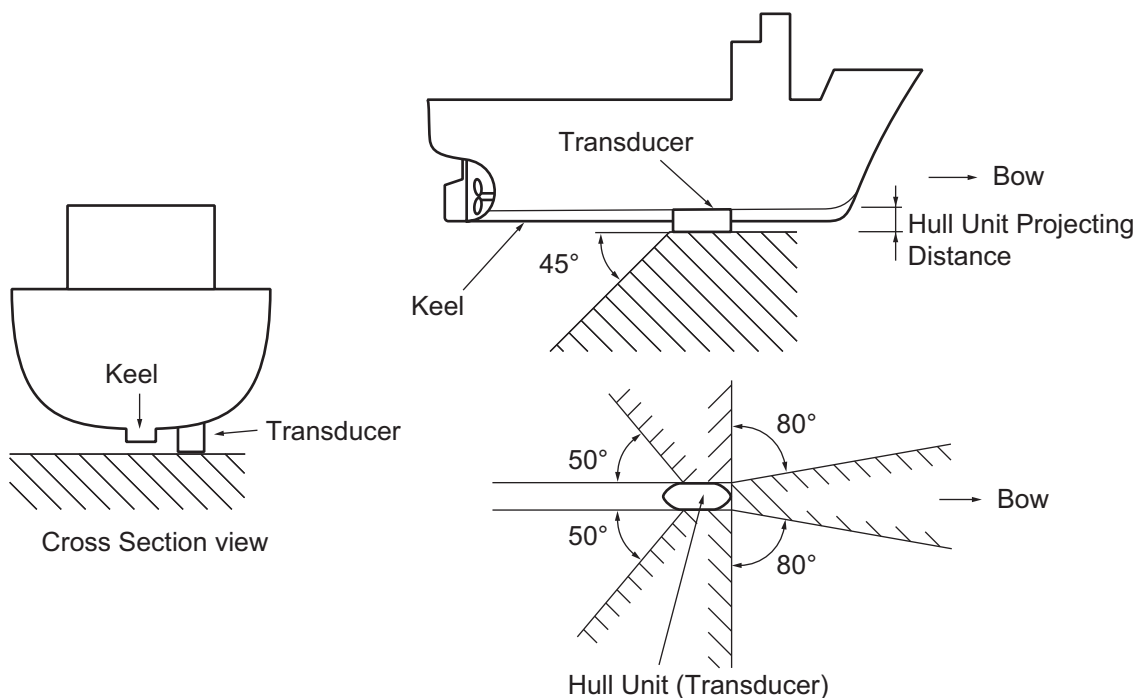

Transducer, mounting location

- b) Mount the transducer at a location between one-third and one-half of the ship's full length (measuring from the bow). Select a place where the transducer is free from

1. INSTALLATION OVERVIEW

the effects of air bubbles. The transducer face should not be above the sea surface when the ship is pitching or rolling.

- c) In general, the air bubbles produced at the bow flow backward alongside the keel. Therefore, separate the transducer by more than 1000 mm from the keel, or flush mount the transducer inside the keel.
- d) The surface of the transducer should project by 250 mm or more from the hull bottom. For better performance, its surface should be even with the keel's lowest point or below it.
- e) The following is important for preventing interference between the CI-68 and other equipment. If the transducer of an echo sounder or scanning sonar whose harmonic is within the frequency range of 236 kHz to 252 kHz (244±8 kHz) is mounted, interference may occur. Even if the harmonic is out of the range, the risk of interference still exists if the transducer of the CI-68 and other equipment are mounted near one another. For this reason, separate the transducer of the CI-68 as far as practical from other equipment which have high output power. If interference is unavoidable due to limited mounting space, connect the interfering equipment to the built-in interference rejection circuit (two inputs) in the transceiver unit. For connection to this circuit, you will need to run a two-cores cable between it and the interfering equipment.
- f) Make the transducer cable as short as possible. The cable is generally installed in grounded steel conduit run between the transducer and the junction box, to prevent pick-up of noise. The transducer with the 20 m transducer cable can be used only when it is passed inside conduit.

NOTE

-  **Do not transport the transducer by pulling the transducer cable.**

The internal wiring may be cut.

WARNING

-  **Install the specified transducer tank in accordance with the installation instructions. If a different tank is to be installed the shipyard is solely responsible for its installation, and it should be installed so the hull will not be damaged if the tank strikes an object.**

The tank or hull may be damaged if the tank strikes an object.

-  **If a steel tank is installed on an FRP vessel, take appropriate measurements to prevent electrolytic corrosion.**

Electrolytic corrosion can damage the hull.

1.2 Ground

This equipment uses pulse signals which may cause interference to other electronic equipment such as a direction finder and radio receiver, if it is not grounded properly. It is strongly recommended to ground all cables referring to the guidelines below.

- a) Separate all units as far as possible from radio equipment.
- b) Do not run interconnection cables close to or near radio equipment or its cables.
- c) Run the cables in the shortest path practical.
- d) Lay the cables on grounded copper plate and fix them every 300 mm with metal cable clamps.
- e) Ground all units as shown in the figure below and on the next page.
- f) To join copper straps, use solder cream for perfect contact.

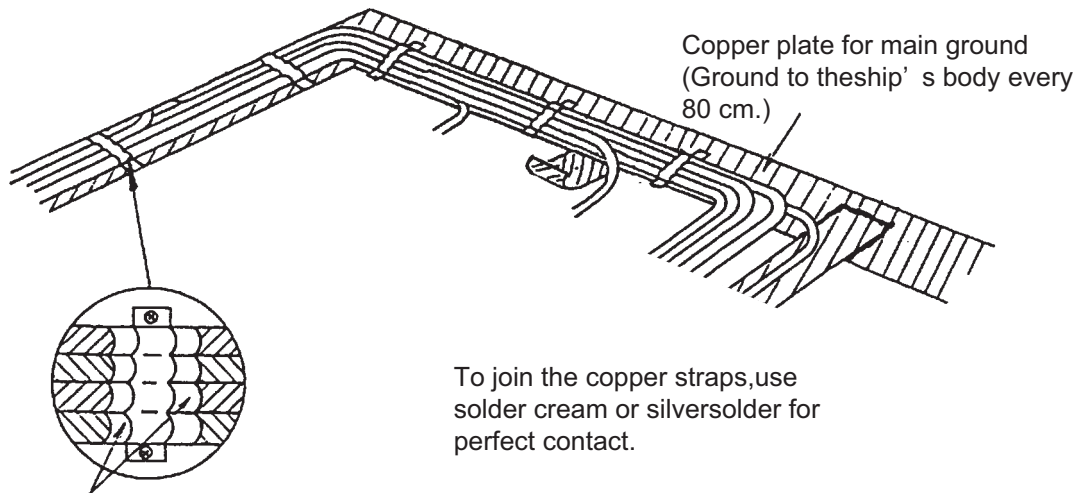

Scrape off paint; ground the armor with a metal cable clamp.

Example of ground

Location of earth terminal on each unit and grounding method

 <h1 style="margin: 0;">CAUTION</h1>	
	<p>Ground the equipment.</p> <p>Ungrounded equipment can give off or receive electromagnetic interference or cause electrical shock.</p>

1. INSTALLATION OVERVIEW

Monitor unit/Control unit

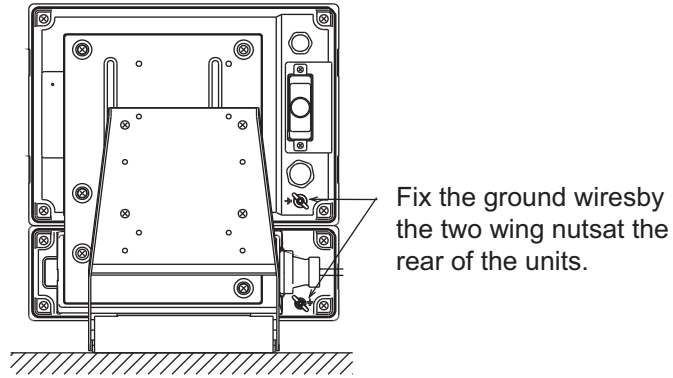

Transceiver unit

This protection earth should be grounded securely.

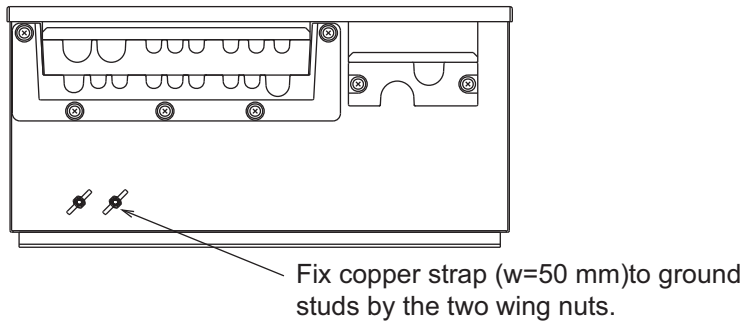

Junction box

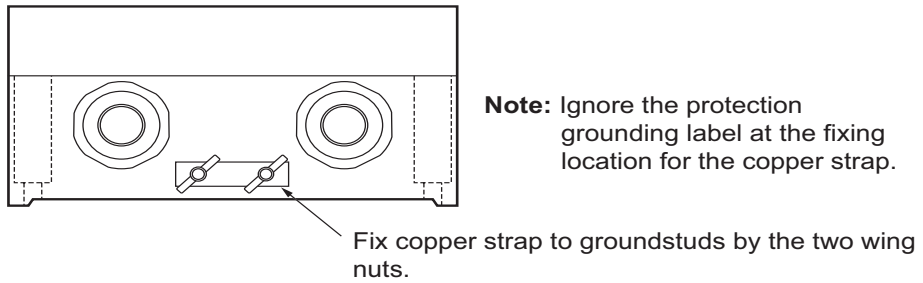

Location of ground terminals

1.3 Changing Power Supply Voltage

1 ϕ , 50/60 Hz AC power is supplied to the transceiver unit. The transformer tap is set at the factory according to customer's order. If necessary, change jumper wires at the terminal board of the transceiver unit according to the input voltage.

⚠ WARNING

⊘ Turn off the power at the power supply before opening the cover.
Fire or electrical shock can result if the power is left on.

⊘ Use the correct fuse.
Use of wrong fuse can result in damage to the equipment.

1. Remove the cover from the transceiver unit.
2. Disconnect the connectors J5 and J8 from the board at the upper of the transceiver unit.

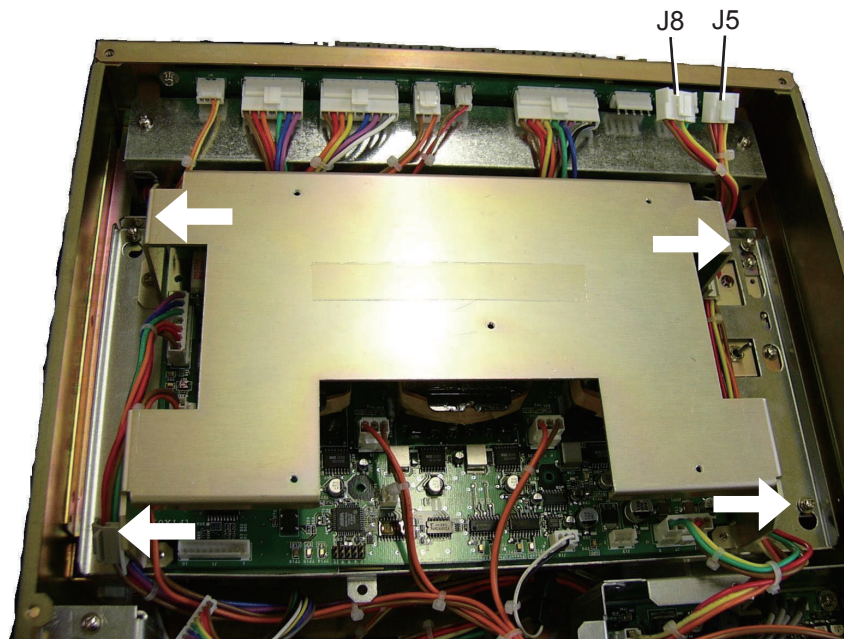

3. Unfasten four screws shown with arrows in above to remove the PTX6 Board.

1. INSTALLATION OVERVIEW

4. Arrange jumper wires depending on the input power voltage, referring to the next page.

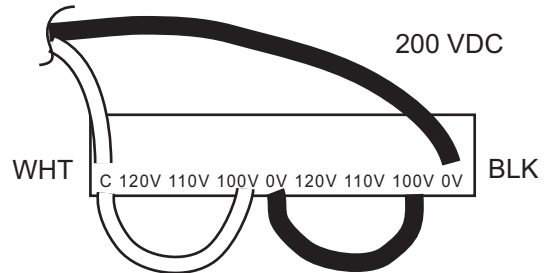
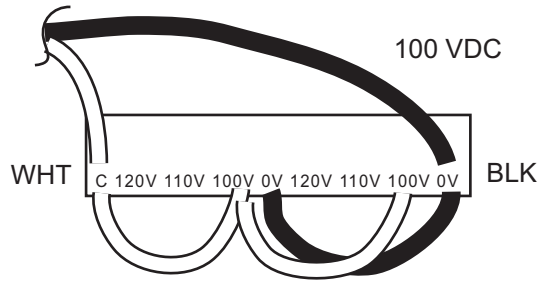
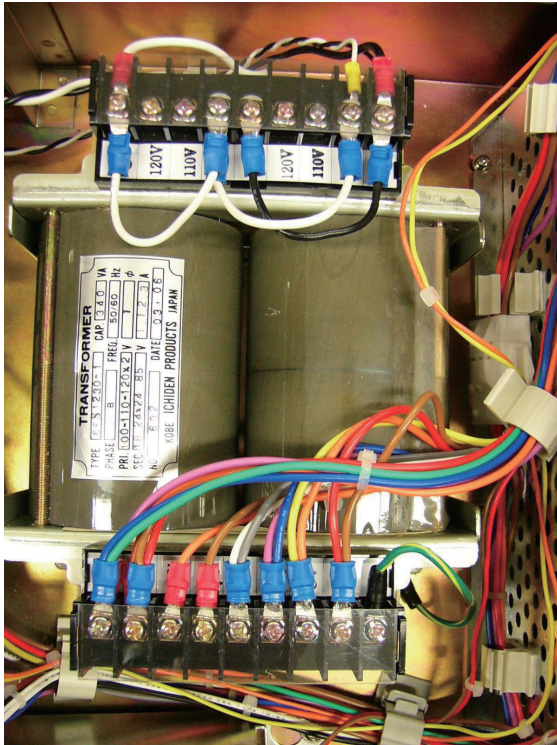

Trans wiring



For other voltages, see the sticker attached at inside of the transceiver unit. Also, exchange the FUSE 1 and FUSE 2 fuses as below.

	FUSE1	FUSE2
100 VAC	FGBO 5A AC250V	FGBO 5A AC250V
200 VAC	FGBO 3A AC250V	FGBO 3A AC250V

Note: After changing the power voltage, check the appropriate box on the above sticker according to the voltage.

2. MOUNTING

2.1 Monitor Unit/Control Unit

	WARNING
	Turn off the power at the switchboard before beginning the installation.
	Fire or electrical shock can result if the power is left on.

NOTICE
Do not apply paint, anti-corrosive sealant or contact spray to coating or plastic parts of the equipment.
Those items contain organic solvents that can damage coating and plastic parts, especially plastic connectors.

The monitor and control units can be installed as one unit or two separate units. The optional "separate monitor unit installation kit" is necessary when installing them as separate units. See "Mounting the control unit separately" on page 2-3. Further, these units can be mounted in a panel (requires optional flush mount kit), together or separately. See the outline drawings at the back of this manual for details.

- Locate the units out of direct sunlight and hot air.
- The operator should face the bow while viewing the display screen.
- Select a location where the display screen can be easily observed while operating the control unit.
- Environmental temperature should be -15 to 55°.
- Select the place well-ventilated.
- Locate the units at the place with minimal vibration.
- Keep the unit away from the magnetic field.
- Leave sufficient space around the units for maintenance and servicing. Recommended maintenance space appears in the outline drawing at the back of this manual.

Desktop mounting

Monitor unit and control unit

1. Fasten the mounting base to the mounting location with four tapping screws (5x20).

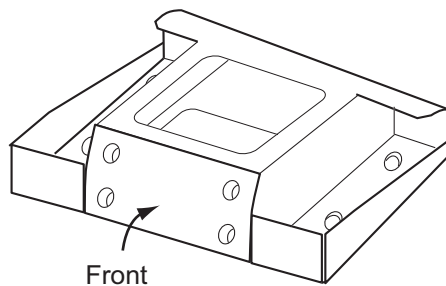

Mounting base

2. MOUNTING

2. Mounting the monitor unit together with the control unit

Fasten the hanger at the rear of the monitor unit with four binding screws (M4x10).

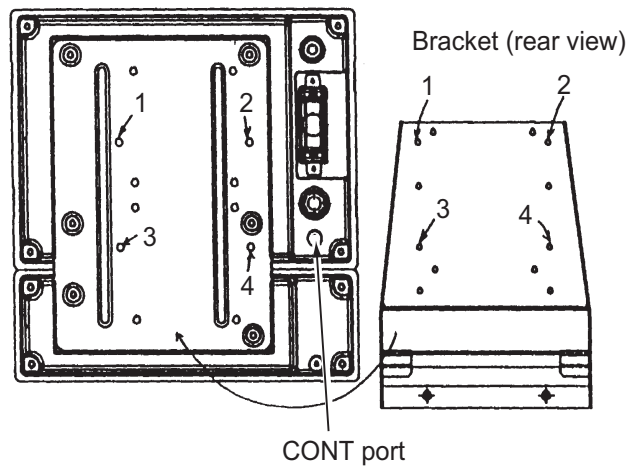

Hanger (landscape-type)

Mounting the monitor unit separately from the control unit

- 1) Dismount the coupling plate from the rear of the monitor unit to separate the monitor unit from control unit.
- 2) Attach the hanger at the rear of the monitor unit with four binding screws (M4x10).

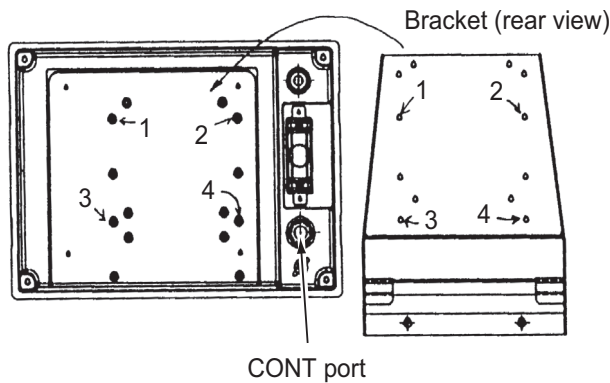

Monitor unit, rear view

3. Grease threads of upset screws (M6x16, 2 pcs.) used to fasten the hanger to the mounting base.
4. Attach the waterproofing cap (MJ-A10C, supplied as the installation materials) to the CONT port at the back of the monitor unit.

5. Fasten the hanger (or monitor unit) to the mounting base with two upset screws. (Use the upper holes to tilt the monitor unit 20°; lower holes to tilt it 9°.)

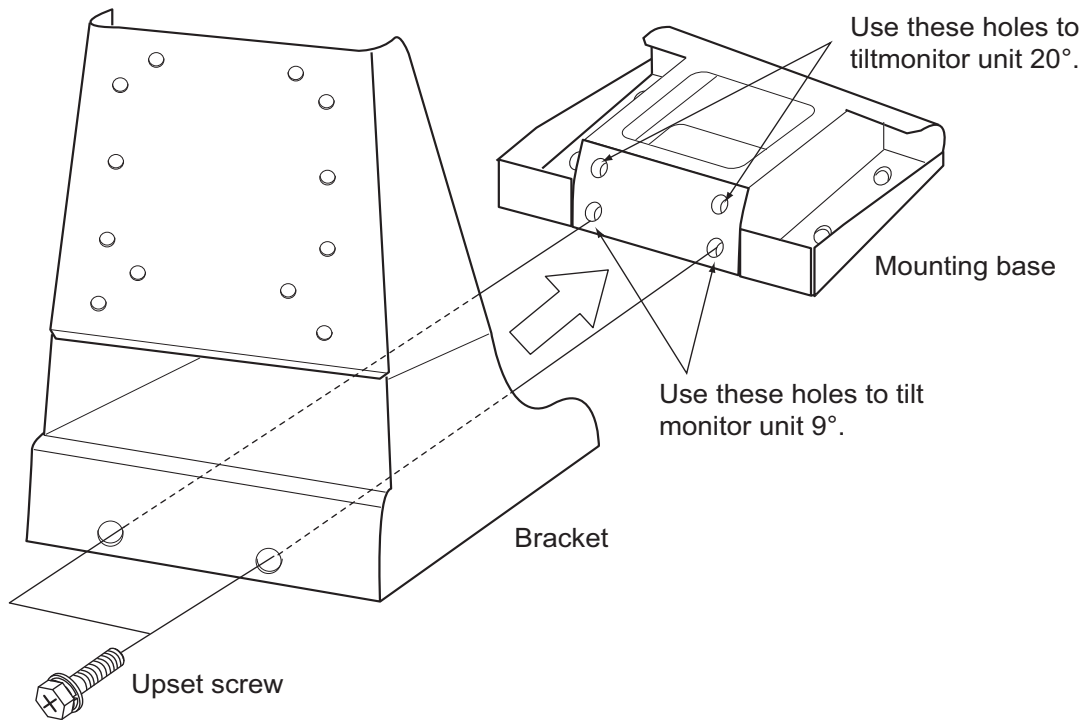

Mounting the control unit separately

To mount the control unit separately or without the monitor unit, one of the following accessories (option) is required.

Type: FP66-00601, Code No.: 006-916-680

Name	Type	Code No.	Qty
Bracket	66-030-3021	100-307-800	1
Tapping screw	4x16 SUS304	000-802-080	4
Pan head screw	M4x10 C2700W	000-881-964	2

Type: FP06-01120, Code No.: 006-556-260

Name	Type	Code No.	Qty
Mounting plate	06-021-2111	100-279-740	1
Bracket	06-021-2112	100-281-880	1
Tapping screw	5x20	000-802-081	2
Hex. screw	M4x12	000-882-040	4
Hole plug	DP-687	000-808-417	2

2. MOUNTING

Using the FP66-00601

1. Fasten the bracket to the control unit, using two pan head screws (M4x10).

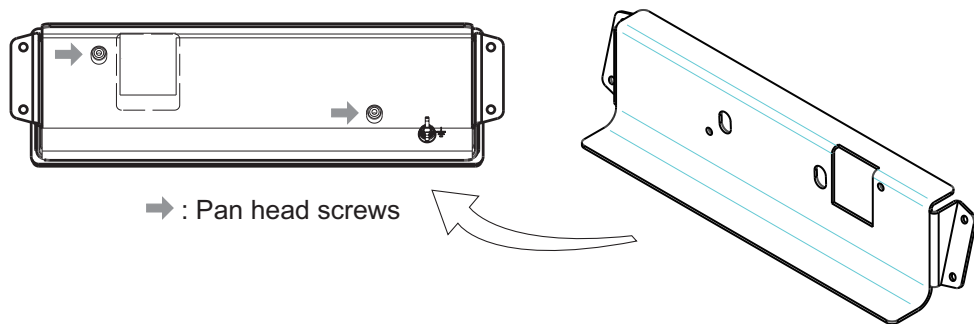

2. Fasten the bracket to the mounting location with four 4x16 tapping screws.

Using the FP06-01120

1. Fasten the mounting plate to the mounting location with two 5x20 tapping screws.
2. Fix the bracket to the control unit with two hex. screws (M4x12).
3. Insert screwdriver from the top of the mounting plate holes and then loosely fasten two hex. screws (M4x12).

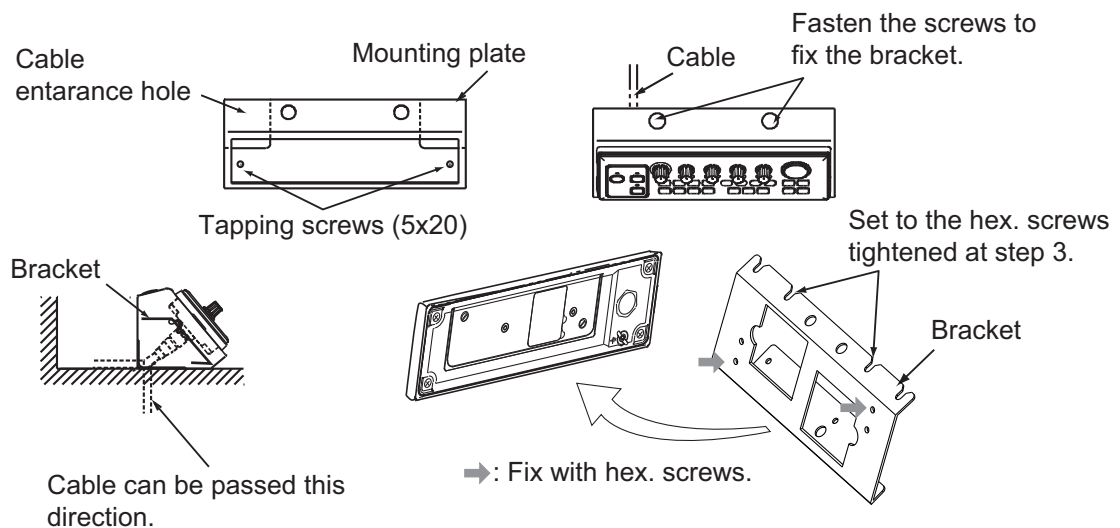

Mounting the control unit

4. Attach the control unit to the mounting plate and then tightly fasten two hex. screws.
5. Attach two hole plugs to the holes at the top of the mounting plate.

Flush mounting

See the outline drawing at the back of this manual.

Monitor unit/control unit

The optional flush mount kit OP06-16 is required.

Type: OP06-16, Code No.: 006-556-300

Name	Type	Code. No.	Qty
Fixing metal	06-021-1311	100-279-611	1
Tapping screw	5x20	000-802-840	6
Hex. bolt	M4x12	000-882-040	4

1. Cut out hole in mounting location referring to the outline drawings at the back of this manual.
2. Fasten the fixing metal to the monitor and control units with four hex. bolts (M4x12).

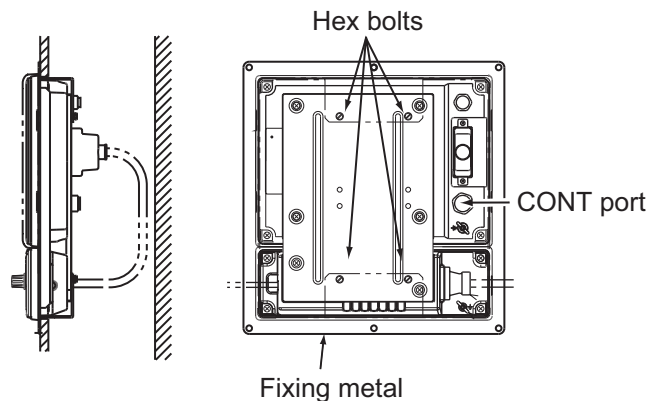

Monitor unit/control unit, rear view

3. Attach the waterproofing cap (MJ-A10C, supplied as installation materials) to the CONT port at the back of the monitor unit.
4. Using four tapping screws (5x20), fasten the fixing metal attached at step 2 to the mounting location.

Monitor unit

For flush mounting of the monitor unit, the following optional kit is required.

Type: OP06-17, Code No.: 006-556-310

Name	Type	Code No.	Qty
Fixing metal	06-021-1321	100-279-622	1
Tapping screw	5x20	000-802-840	4
Hex. bolt	M4x12	000-882-040	4

1. Cut out a hole (H207xW287) in the mounting location referring to the outline drawings at the back of this manual.

2. MOUNTING

2. Fasten the fixing metal to the monitor unit with four hex. bolts (M4x12).

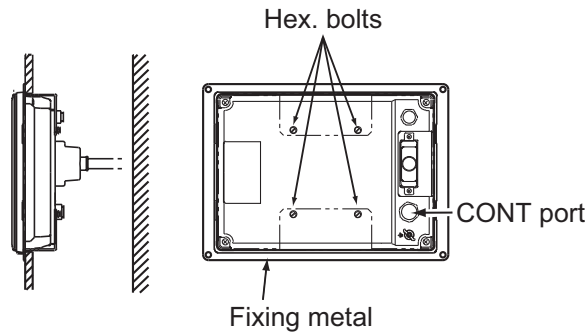

Monitor unit, rear view

3. Attach the waterproofing cap (MJ-10C, supplied as the installation materials) to the CONT port at the back of the monitor unit.
4. Using four tapping screws (5x20), fasten the fixing metal attached at step 2 to the mounting location.

Control unit

Type: OP06-18, Code No.: 006-556-320

Name	Type	Code No.	Qty
Fixing metal	06-021-2101	100-279-731	1
Tapping screw	5x20	000-802-840	4
Hex. bolt	M4x12	000-882-040	2

1. Cut out a hole in the mounting location referring to the outline drawings at the back of this manual.
2. Fasten two hex. bolts (M4x12) to fix the fixing metal to the control unit.

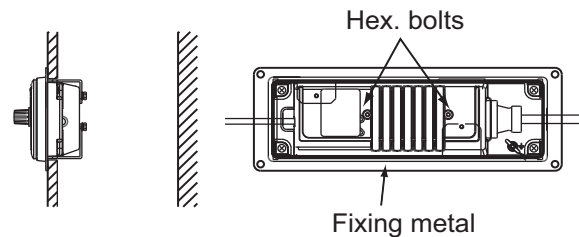

3. Fasten four tapping screws (5x20) to fix the control unit to the mounting location.

Blackbox type

Supply monitor and interconnection cable (D-sub connector, three rows of 15 pins, max. length 15 m) locally. The monitor connects to the control unit, and should satisfy the specifications shown below.

Note: The D-sub connector with two rows of 15 pins cannot be used.

VGA type

- Analog RGB, 0.7 Vpp, positive polarity
- TLL level H, V, negative polarity

2.2 Transceiver Unit

Mounting considerations

- Since the transceiver unit generates heat, install it in a dry, well-ventilated place. The cooling fans at the top of the unit must not be obstructed, to allow heat to escape.
- This unit is designed for bulkhead mounting to permit dissipation of heat. If bulkhead mounting is absolutely impossible, mount the unit on the floor leaving at least 50 mm clearance between it and the floor to permit dissipation of heat.
- This unit weights 19 kg. Reinforce the mounting area, if necessary.
- Leave space around the unit for maintenance and checking. Refer to the drawing at the back of this manual.

Mounting procedure

1. Weld the steel plate (shipyard supply) with four mounting holes to the bulkhead.
2. Use four bolts and nuts (M10, supplied as installation material) to fix the transceiver unit to the steel plate described at step 1.

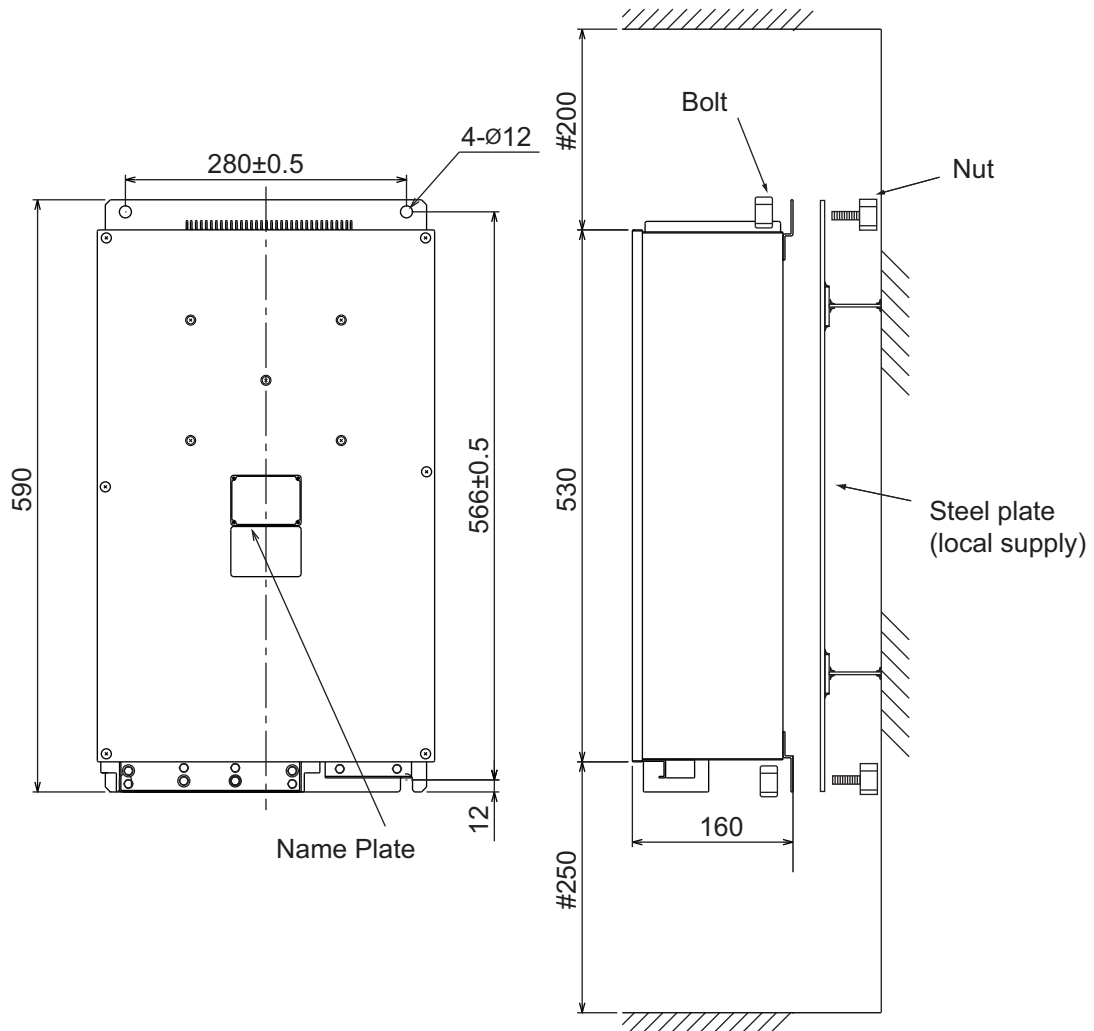

Transceiver unit, mounting dimensions (mm)

2.3 Junction Box (option)

Mounting considerations

The junction box forms a joint between the transducer and the transceiver unit. Install it referring to the guidelines below.

- Keep the junction box away from noise-emitting electrical machinery, i.e., electric generator, radio transmitter, TV, etc.
- Although the box is splashproof, do not install it in places of high humidity.
- Avoid installing the box where temperature varies greatly, since moisture may penetrate the box.
- The box is generally installed above the draft line of the ship and the transducer cable is run inside steel conduit. This permits replacement of the transducer without dry docking.
- Even if the junction box is installed below the draft line, the conduit is necessary to avoid picking up noise. If use of conduit is not possible, install the box as near to the transducer as possible.

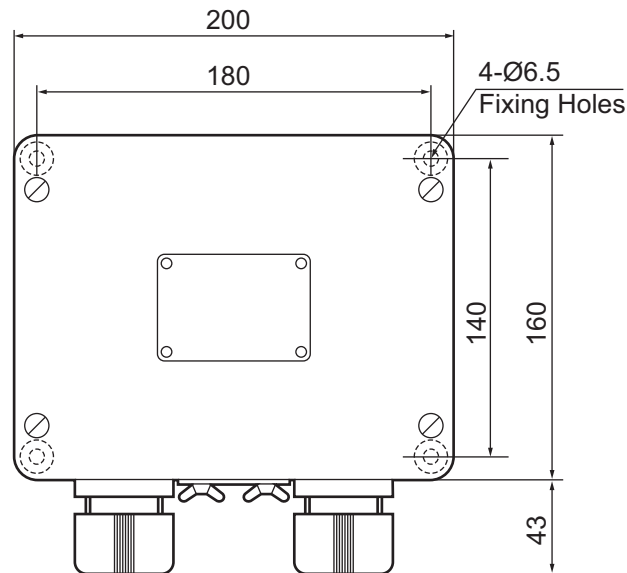

Junction box, mounting dimensions (mm)

Mounting procedure

Fix the junction box to a bulkhead, referring to the figure above for mounting dimensions.

2.4 Transducer (Hull Unit)

See chapter 1 to mount the transducer.

NOTE



Do not transport the transducer by pulling the transducer cable.

The internal wiring may be cut.

Mounting the transducer for steel hull vessels

To mount the transducer for steel hull vessels, the optional transducer casing (CI-620-T-S) and thru-hull pipe (CI-620-K-S) are required.

1. Select a mounting place on the hull bottom. (Since the transducer cable is comparatively thick, select a mounting place for the thru-hull pipe where the cable can be easily led into the cable gland.)
2. If necessary, weld a doubling plate (shipyard supply) to the hull bottom to reinforce the hull.
3. Unpack the transducer casing and determine the projecting length, making it 250 mm or more. Before cutting the casing, note that the transducer casing has fore-aft direction. Then, cut it considering the rising angle of the ship's hull.
Note: Weld the casing in parallel with ship's fore-aft line with an accuracy of better than $\pm 1^\circ$. The transducer face should be horizontal at cruising speed.
4. Make a hole for the thru-hull pipe in the hull bottom. Before welding the thru-hull pipe, remove the rubber packing from the thru-hull pipe. Weld the thru-hull pipe. Replace the rubber gasket.
5. Make a hole of 10 to 20 mm diameter on the stern side of the casing to allow water to penetrate the transducer casing.
6. Weld the casing to the hull bottom. Do not remove the transducer fixing flange to prevent the casing from being deformed.

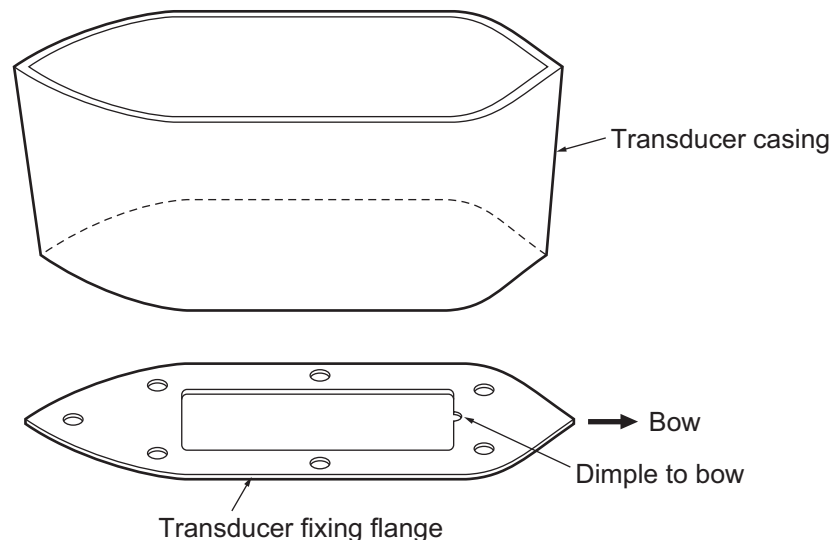

Fixing transducer casing

7. Dismount the fixing flange from the casing. Fix the transducer to the fixing flange.

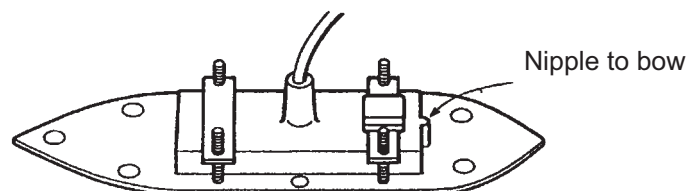

Fixing flange

2. MOUNTING

8. Pass the transducer cable through the thru-hull pipe. Tighten the cable gland, leaving 0.5 to 1 m of slack in the cable below the cable gland.

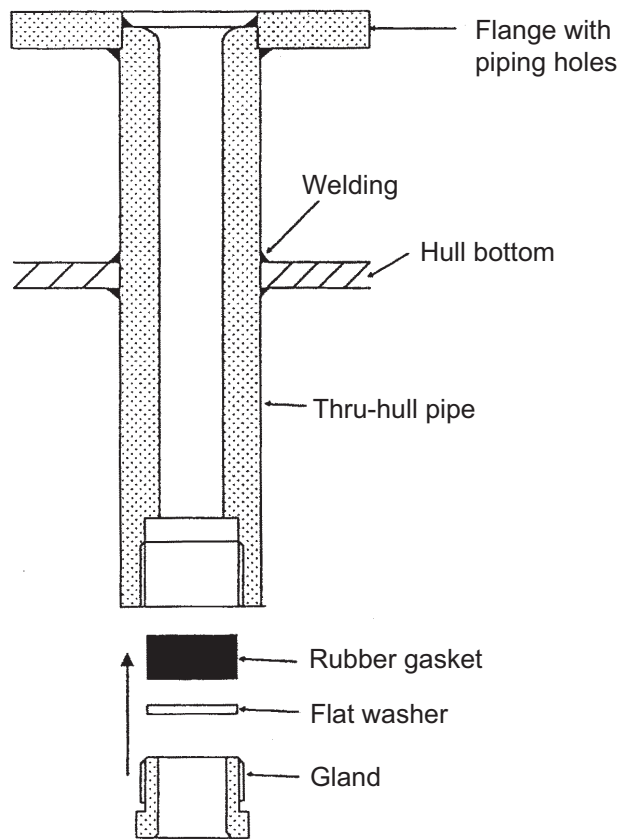

Thru-hull pipe for steel hull

9. Mount the fixing flange with the transducer onto the casing. Take care not to pinch the transducer cable. Never hold the transducer by the cable. Shock will most assuredly damage the transducer.

Mounting the transducer for FRP hull vessels

1. Select a mounting place on the hull bottom. (Since the transducer cable is comparatively thick, select a mounting place for the thru-hull pipe where the cable can be easily led into the cable gland.)
2. Determine the projecting length of the casing, making it at least 250 mm. Cut the casing, considering the rising angle of the ship's hull, so that the transducer face is horizontal.
Note: The casing should be parallel with ship's fore-aft line within $\pm 1^\circ$, and the transducer face should be horizontal at cruising speed.
3. Make a hole of 10 to 20 mm in diameter on the stern side of the casing to allow water to penetrate the transducer casing.
4. Make a hole for the thru-hull pipe on the hull bottom. Allow enough clearance around the pipe for easy tightening of lock nuts.
5. Fix the thru-hull pipe on the hull plate with double nuts and then apply FRP glue around the pipe.
6. Before fixing the casing to the hull bottom, clean the hull plate surface with an electric sander until fiberglass appears, then remove dusts, oils, etc. from surface. Reinforce both sides of the casing with FRP molding.

7. Fix the transducer to the fixing flange.

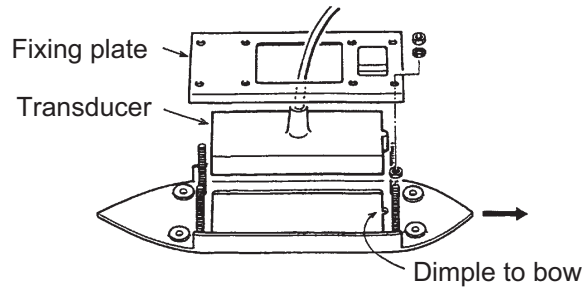

Transducer and fixing flange

8. Pass the transducer cable through the thru-hull pipe. Tighten the cable gland, leaving 0.5 to 1.0 m of slack in the cable below the cable gland.

To tighten the cable gland

- 1) Tighten the gland securely by using the wrench.
- 2) Tighten the double nut securely.

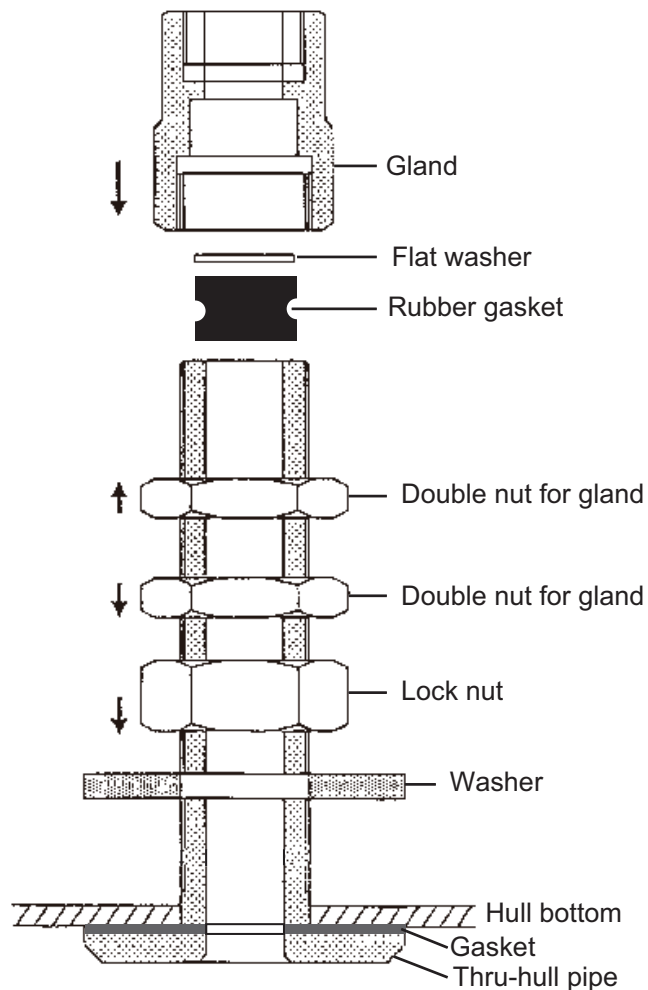

Thru-hull pipe, side view

9. Fix the fixing flange with the transducer to the casing. Take care not to pinch the transducer cable.

2.5 DC/AC Inverter

If the power supply is 24 VDC, the DC-AC inverter is required. This unit is designed for the bulkhead mounting and weights 15 kg, reinforce the mounting location if necessary. The cable entrances must be faced downward.

Note: Mount this unit in a well-ventilated place to prevent heat build up inside the cabinet.

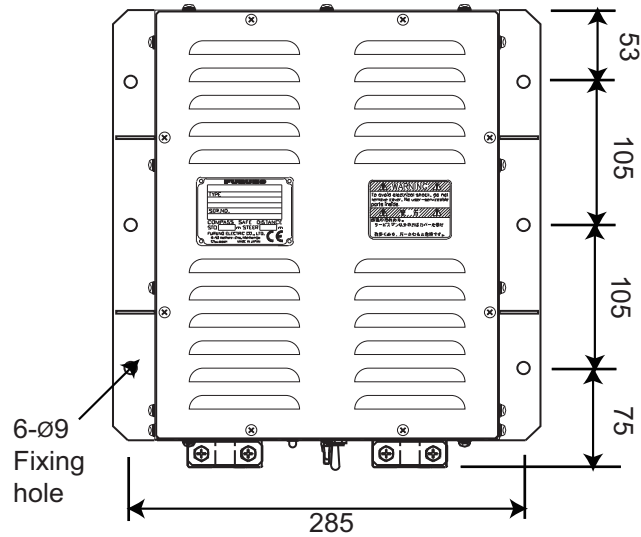

DC-AC inverter, mounting dimensions (mm)

3. WIRING

See the interconnection diagram at the back of this manual.

3.1 Wiring the Control Unit

3.1.1 Connection with the transceiver unit

Attach the connector of the control unit to the cable (66S1238) from the transceiver unit as below.

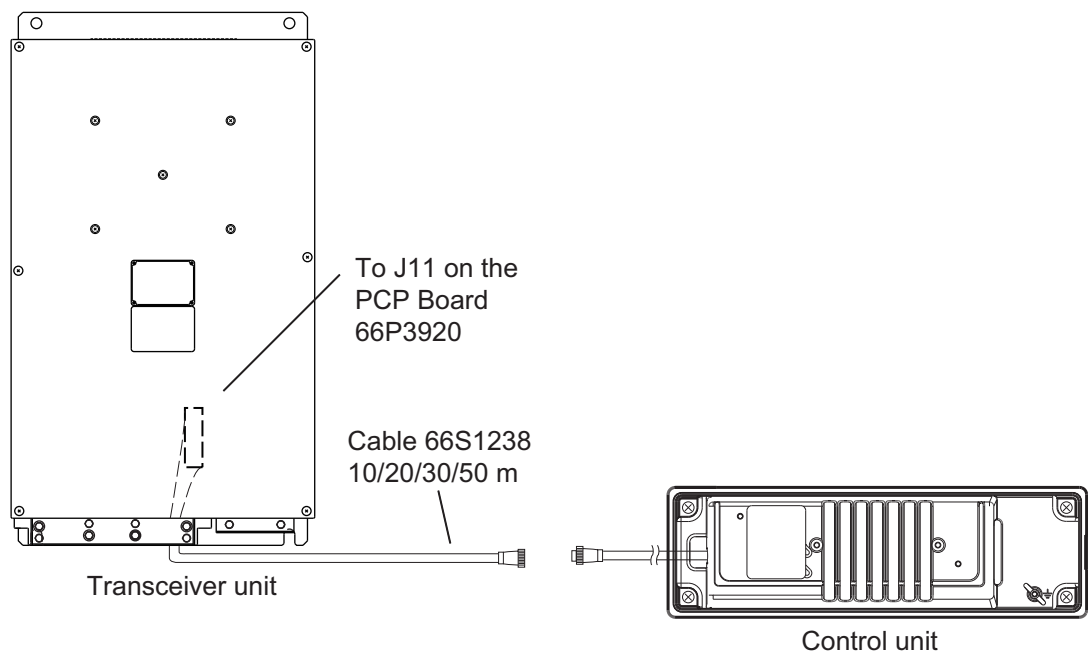

3.1.2 Connection with the monitor unit

Choose one from the follows to connect the control unit and monitor unit (VGA monitor).

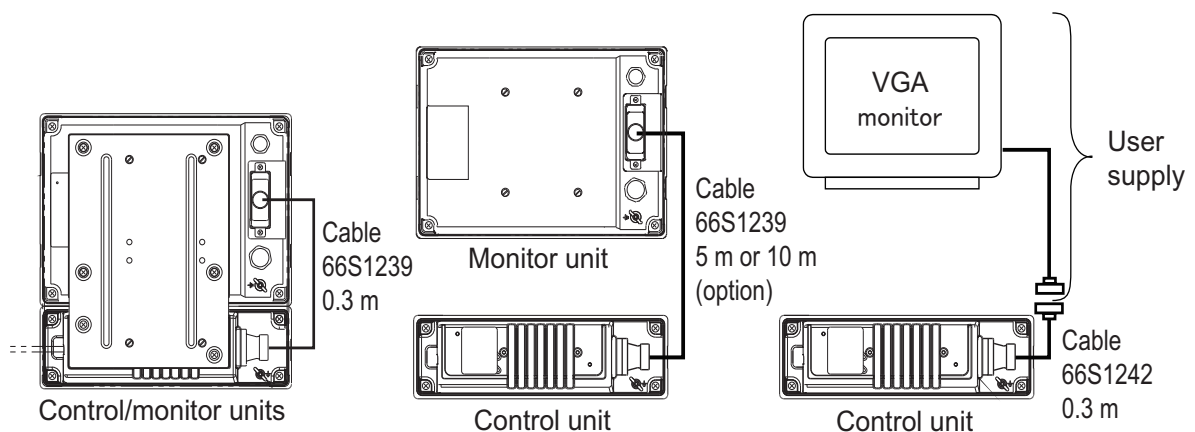

3.2 Wiring the Transceiver Unit

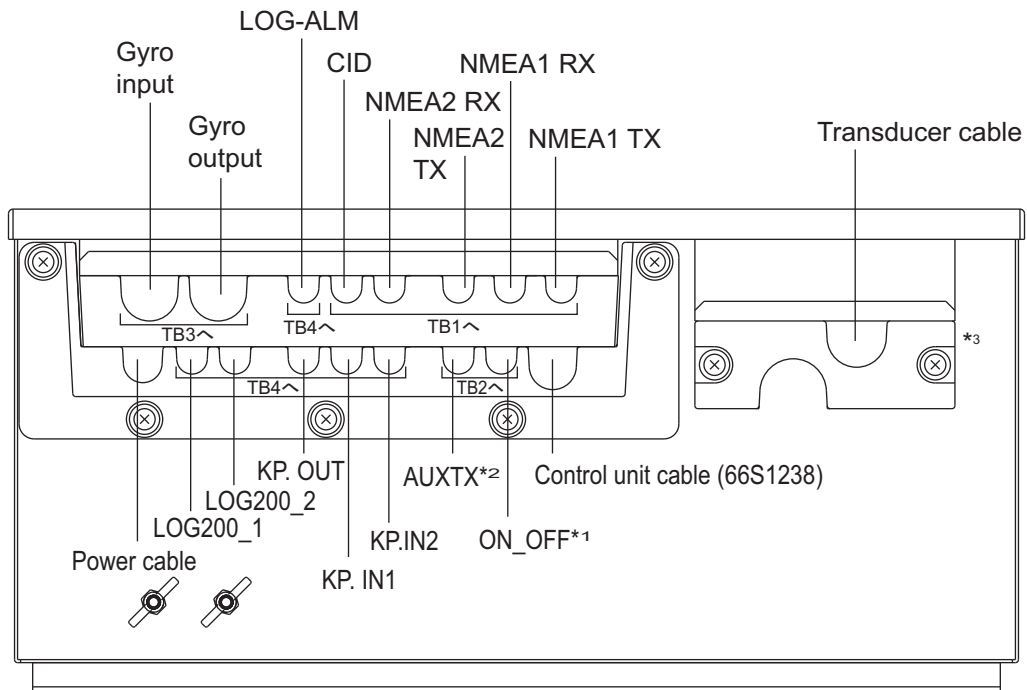

*1: Contact alarm signal

*2: CIF/NMEA/Current

*3: When connecting the cable from the junction box, reverse the direction of the clam

Transceiver unit, bottom view

Fabricating DPYC-2.5 and DPYCY-2.5 (Japanese Industrial Standards) or equivalent cable

DPYC-2.5
(DPYCY-2.5: w/outer sheath)

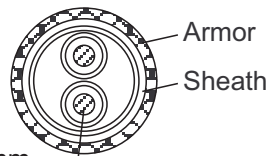

Ø = 12.8 mm
(DPYCY-2.5: 14.8 mm)
Conductor
S = 2.5 mm²
Ø = 2.01 mm

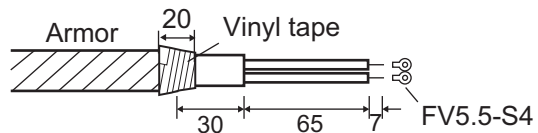

Dimensions: mm

Power cable DPYC-2.5 or DPYCY-2.5

Fabricating 4P cable (66S1067, from the junction box)

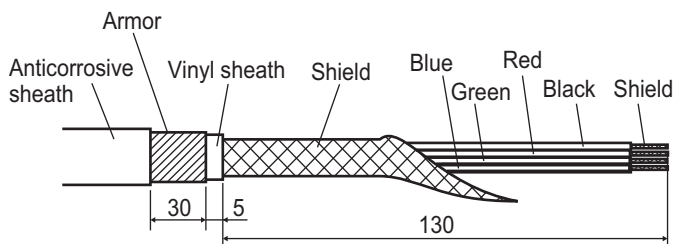

NOTE

! Carefully connect the wires to respective terminals, referring to the illustrations and the interconnection diagram. Wrong connection can damage the transducer.

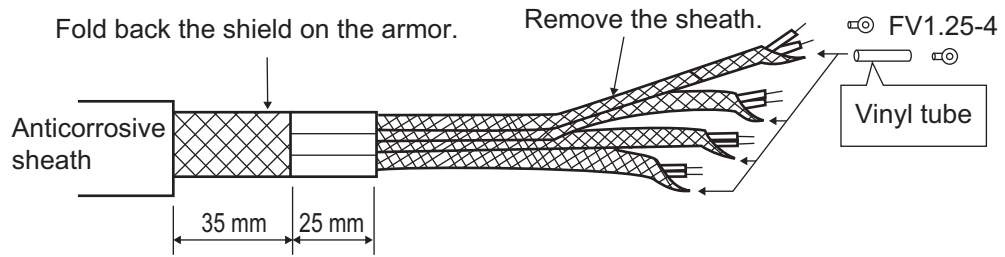

Transducer cable 1

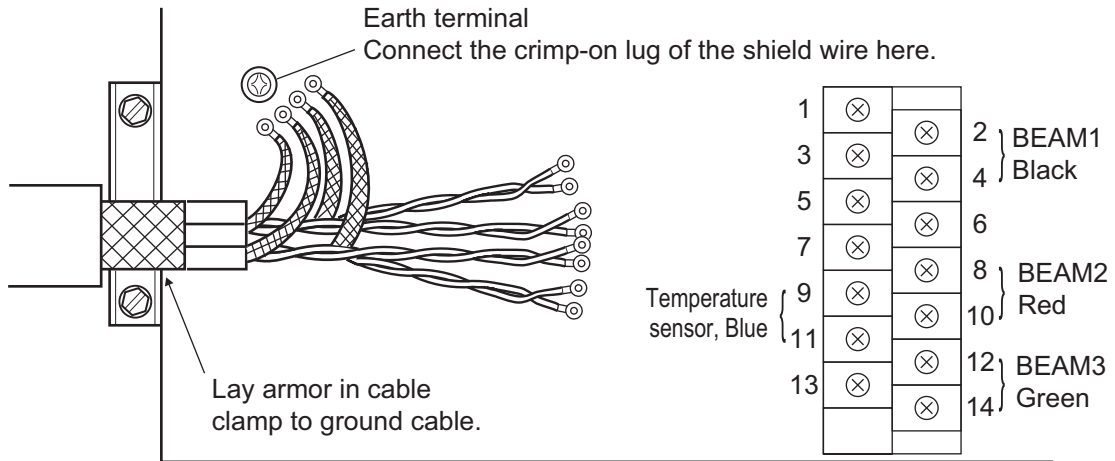

Transducer cable 2

Fabricating of the control unit cable (66S1238)

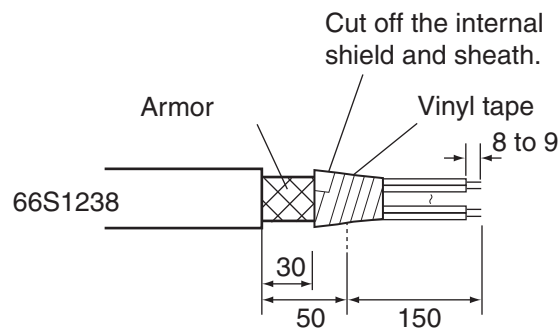

3.3 Connecting the Junction Box

The transducer cable is connected to the junction box with an extension cable. After making the connection, seal the cable gland with putty for watertightness.

Transducer cable (66S1066, no armor)

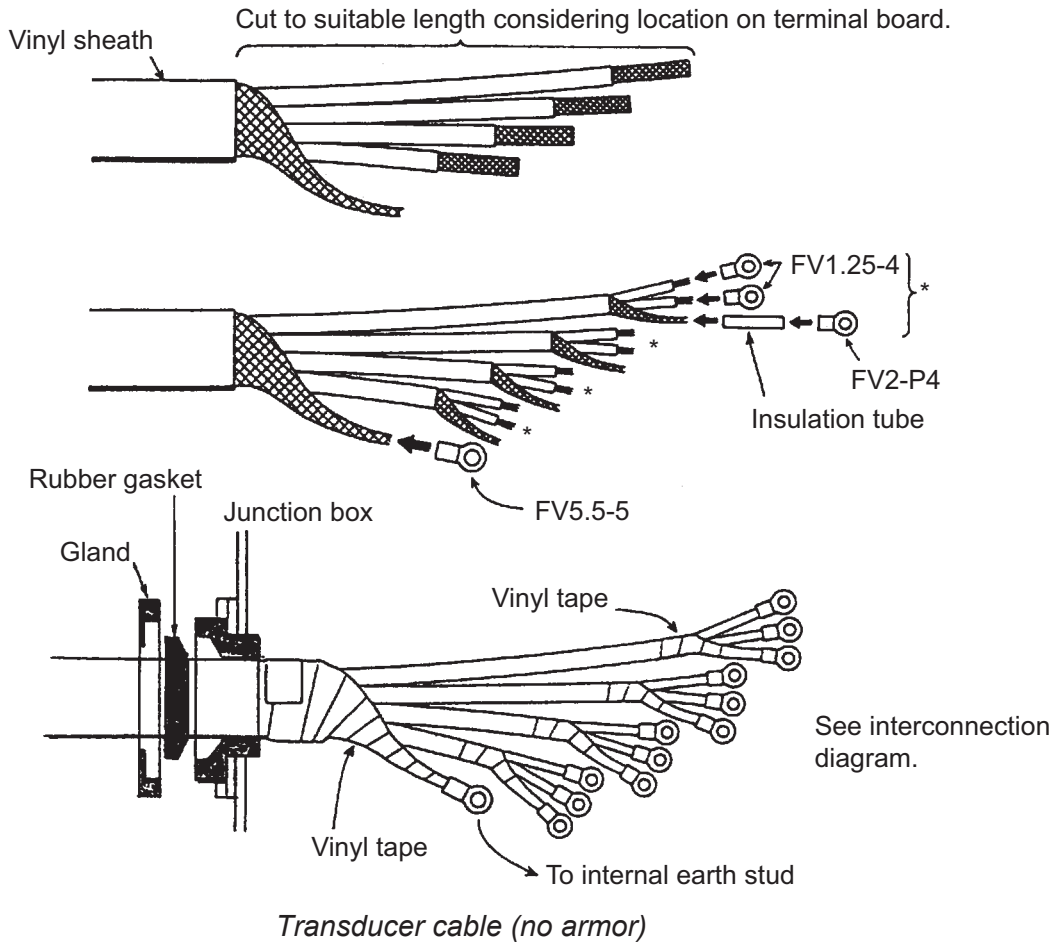

4P pair cable (66S1067, extension cable, with armor)

Attach crimp-on lugs in the same manner as shown above. Fabricate the armor as follows.

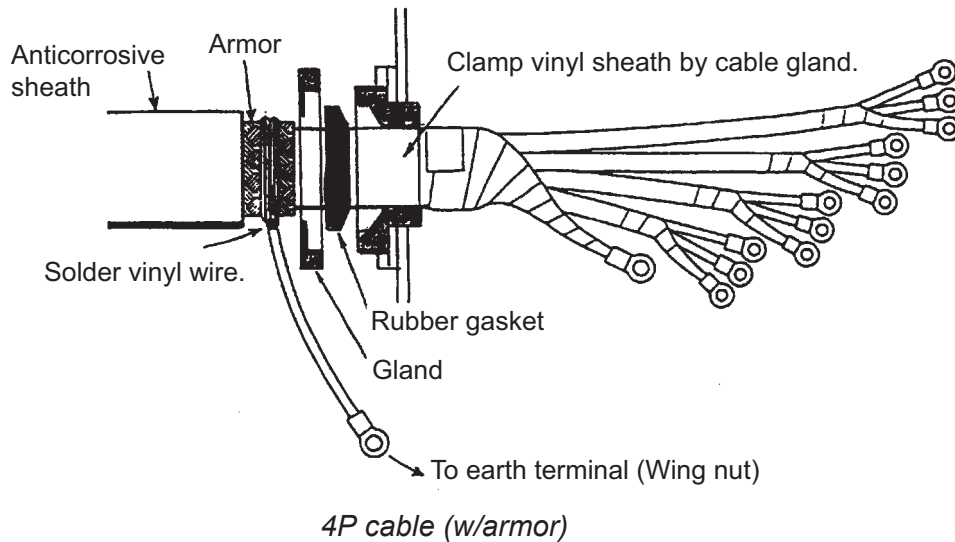

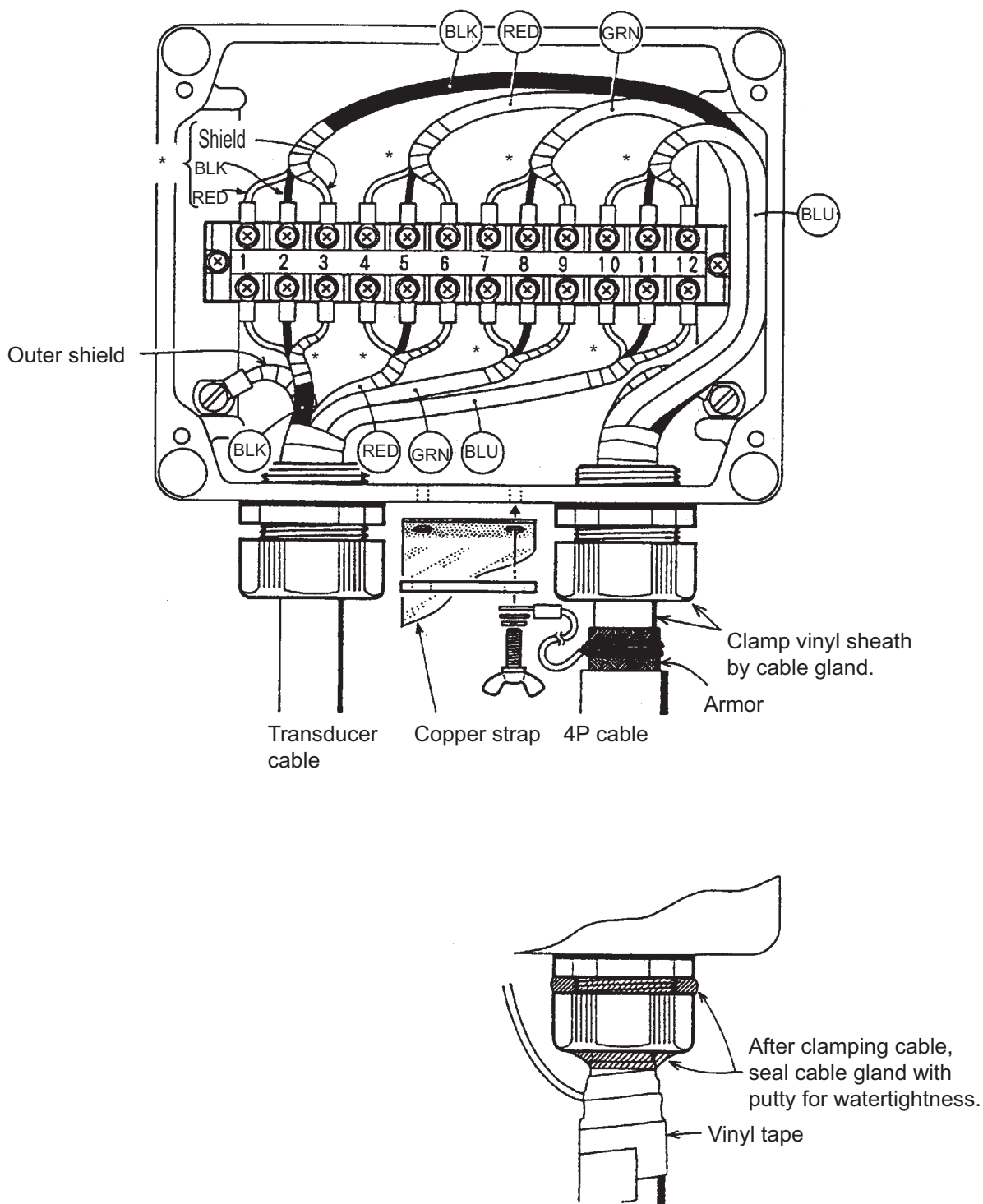

Junction box, inside view

3.4 External Equipment

A gyrocompass, NMEA equipment, LOG pulse and KP signal are connected to the transceiver unit. Use the connectors attached to the PCN Board (66P3924) in the transceiver unit. Also, the opener is supplied as installation materials for the transceiver unit.

The right figure is the internal view of the transceiver unit.

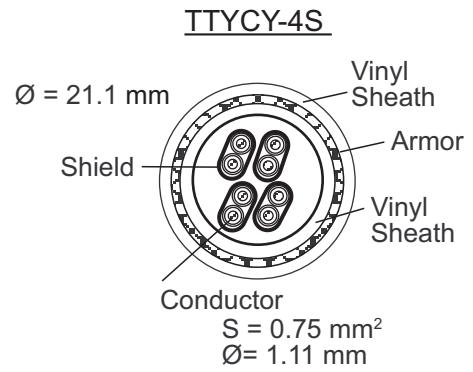
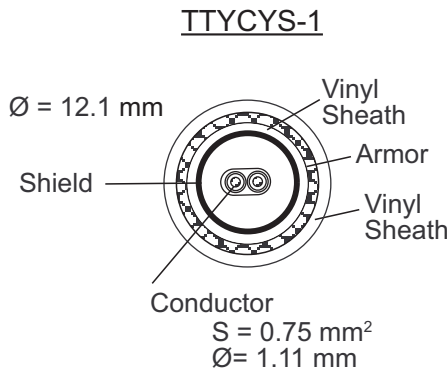
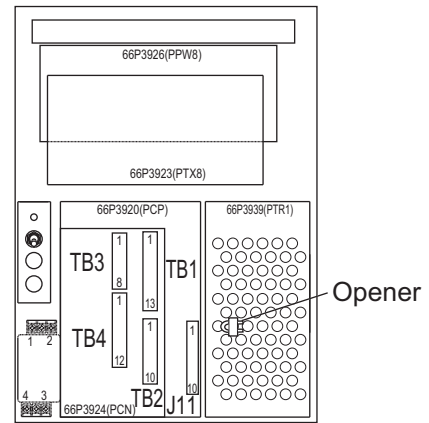

TB1

Use TB1 to transmit/receive NMEA and current indicator's signal.

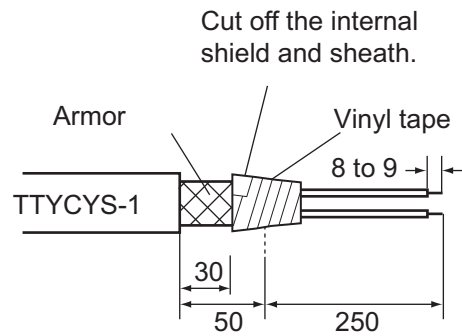

TB2

Use TB2 to output RS-422 (ship's speed, current data etc.) and power ON/OFF (contact signal).

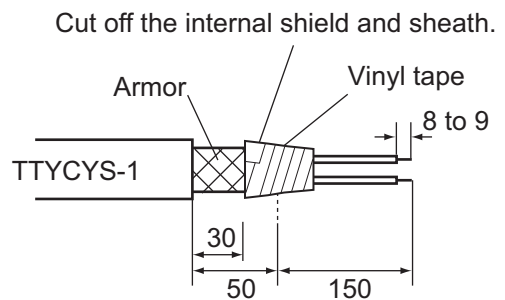

TB3

Use TB3 to input/output GYRO signal.

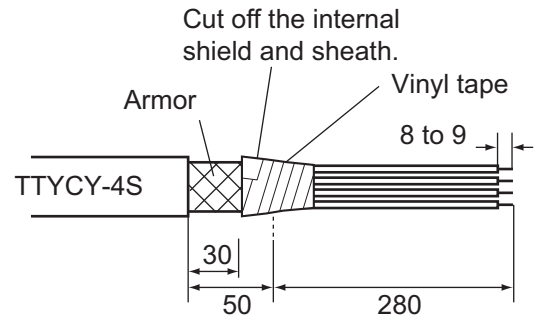

TB4

Use TB4 to input/output the following signal.

- Alarm signal Output
- Log signal Output
- KP signal Input
- KP signal Output

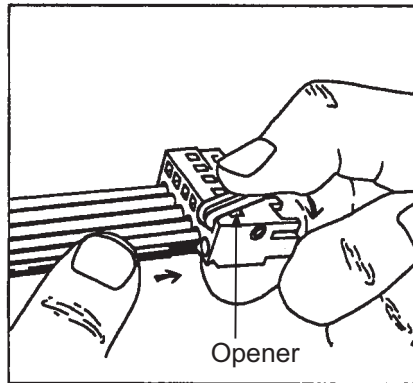
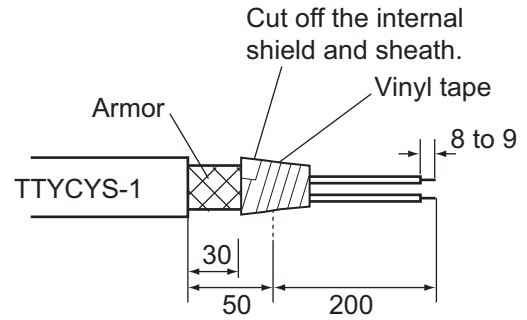

1. Attach the opener to the connector.
2. Push the opener.
3. Insert the cable core.
4. Release the opener.

How to attach cable core to the connector

3.5 DC/AC Inverter

Use the DPYCY-6 (Japanese Industrial Standards) cable to connect the DC-AC inverter from the ship's power supply within 5 m. For outputting 100VAC, use the DPYCY-2.5 cable.

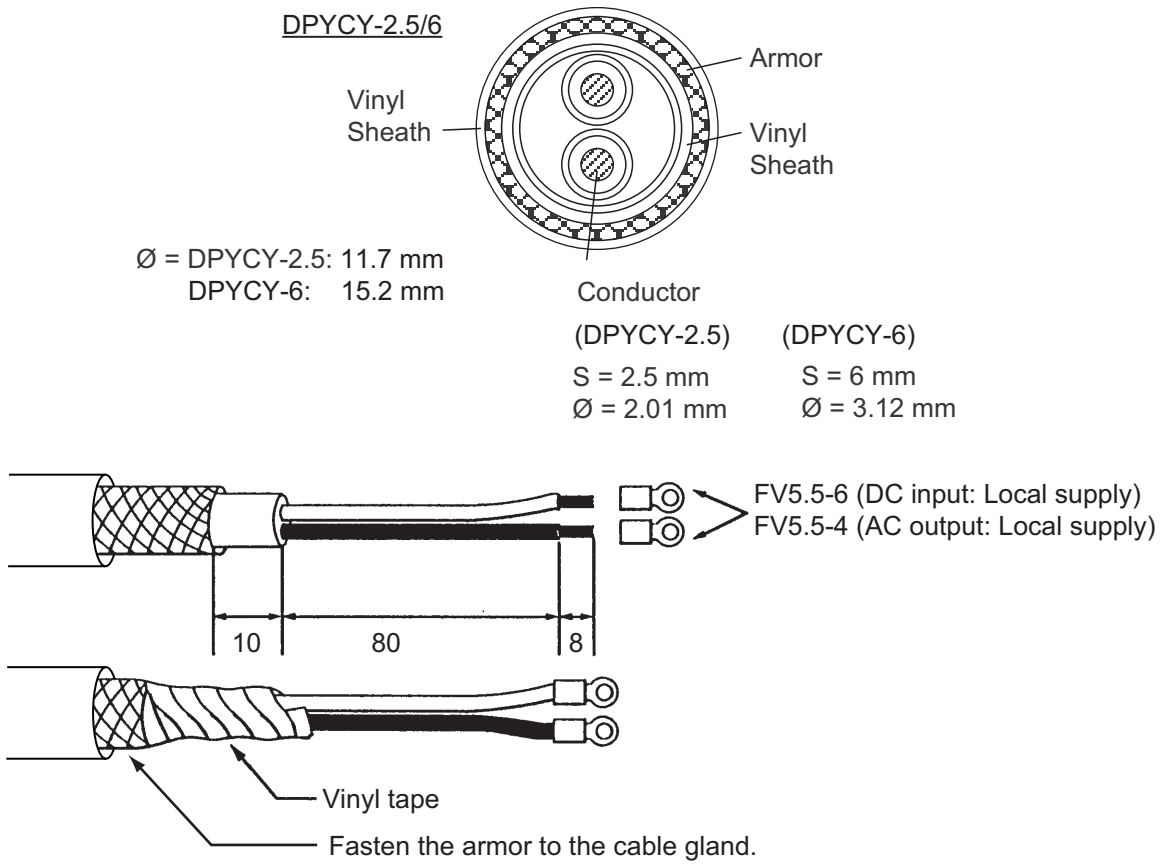

4. ADJUSTMENTS

4.1 [INSTALLATION] menu

4.1.1 [I/O] sub menu

1. Press the **MENU** key.
2. Press **▲** to move the cursor to the top of the menu.
3. Press **▶** several times to show the message "PRESS FUNC KEY TO OPEN INSTALLATION MENU."

Note: Press the **MENU** key to open the menu other than the INSTALLATION menu.

4. Press the **F1** key and then select [INSTALLATION].
5. Press **▼**.
6. Press **◀** to select [I/O].

MENU 1	MENU 2	ALARM	INSTALLATION
			I/O CALIB OTHER
NMEA VERSION	: 1.5 2.0	<input type="text" value="3.0"/>	IEC61162
NMEA PORT 1			
BAUD RATE	: <input type="text" value="4800"/>	38400	
NMEA2/CIF			
FORMAT	: <input type="text" value="NMEA"/>	CIF	
NAV SOURCE	: <input type="text" value="AUTO"/>	GPS	LORAN-C
NAV DATA	: <input type="text" value="SPD"/>	L/L	
TIME INTERVAL*	: <input type="text" value="1 min"/>		
HEADING DEVICE	: <input type="text" value="NO"/>	YES	
FORMAT**	: <input type="text" value="AD-10"/>	NMEA	
HDG OUT > 0.5kn	: <input type="text" value="COG"/>	HEADING	
HDG OUT < 0.5kn	: <input type="text" value="COG"/>	HEADING	
LOG PULSE MODE	: <input type="text" value="GT/WT"/>	WT	
LOG PULSE OUT	: FORE <input type="text" value="FORE/AFT"/>		
TIDE OUT INT	: <input type="text" value="15 sec"/>		
TEMP SENSOR	: NO <input type="text" value="YES"/>		
MENU ON INSTALLATION SETTINGS.			
[▲/▼]:SELECT, [◀/▶]: CHANGE, [MENU]: EXIT			

* Shown when [NAV DATA] is set to [L/L].

** Shown when [HEADING DEVICE] is set to [YES].

[I/O] sub menu

NMEA VERSION

Choose NMEA version of sentences which are output from the NMEA 1 port and NMEA2/CIF port. The choices are NMEA 1.5, 2.0 and 3.0, and IEC61162. The input sentences do not require NMEA version.

NMEA PORT 1 BAUD RATE

Choose baud rate of equipment connected to NMEA 1 port. The choices are 4800 and 38400 (bps).

4. ADJUSTMENTS

NMEA2/CIF FORMAT

Choose format of equipment connected to NMEA2/CIF port. The choices are [NMEA] and [CIF]. When selecting [NMEA] here, the sentences are output with the NMEA version selected at [NMEA VERSION]. The baud rate is fixed to 4800 bps. To choose CIF, set the jumper switch J4 on the PCN Board (66P3924) to CIF.

NAV SOURCE

Choose source of nav data among [AUTO], [GPS] and [LORAN-C]. [AUTO] reads position data in order of accuracy: GPS>LC.

NAV DATA

Choose source data for calculation of sea tide in the NAV mode.

[SPD]: Speed data from the GPS navigator is used as ground tracking speed to calculate sea tide.

[L/L]: Position data from the GPS navigator is used as ground tracking speed to calculate sea tide.

TIME INTERVAL

Set the time interval for reading position data to use for calculating speed. Effective when [NAV DATA] above is selected to [L/L]. The choices are 1, 2, 3 and 4 (min).

HEADING DEVICE

Choose [YES] if a heading device is connected to the current indicator. When [YES] is selected, you can choose [HEAD UP] or [NORTH UP] on the [DISP1] sub menu. For selection of [NO], the display mode is fixed to [HEAD UP].

FORMAT

When [YES] is selected at [HEADING DEVICE] above, choose the format of the heading device which is connected to the current indicator. The choices are [AD-10] and [NMEA].

HDG OUT >0.5kn

Choose type of bearing to output when ship's speed is higher than 0.5 kn. The choices are [COG] (Course Over Ground) and [HEADING].

HDG OUT <0.5kn

Choose type of bearing to output when ship's speed is lower than 0.5 kn. The choices are [COG] (Course Over Ground) and [HEADING].

LOG PULSE MODE

Choose the tracking mode to use as source for the log pulse. The choices are [GT/WT] (ground tracking/water tracking) and [WT] (water tracking).

LOG PULSE OUT

Output log pulse in fore direction or both fore and aft directions.

TIDE OUT INT

Choose the output interval for tide data, from among 15 and 30 seconds, and 1, 2, 5 and 10 minutes.

TEMP SENSOR

Choose [YES] if a water temperature sensor is connected to the current indicator.

4.1.2 [CALIB] sub menu

MENU 1	MENU 2	ALARM	INSTALLATION
			I/O CALIB OTHER
DRAFT	: 0.0m		
HEEL ANGLE	: 0.0°		
TRIM ANGLE	: 0.0°		
GT SPD CALIB	: 0.0%		
WT SPD CALIB	: 0.0%		
BEARING CALIB	: 0.0°		
COURSE CALIB	: 0.0°	(GT: 0.0°	NAV: 0.0°)
CSE CALIB MODE	: GT	NAV	MANUAL
CSE CALIB EXEC*	: NO	YES	
SOUND VELOCITY	: NO	YES	
EXTERNAL KP1	: 0.0m		
EXTERNAL KP2	: 0.0m		

* Shown when [CSE CALIB MODE] is set to [GT] or [NAV].

[CALIB] sub menu

DRAFT

Set ship's draft to get depth from draft rather than transducer. (-5 to 25.5 (m))

HEEL ANGLE

Compensate lateral (port-starboard) inclination of the transducer face. Set [+] angle for port-high state and [-] angle for starboard-high state. (-12.8 to 12.7 (°))

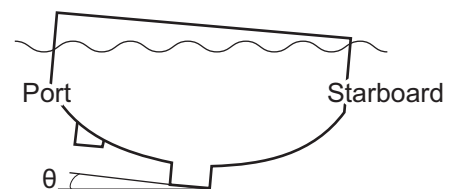

Set to +5.0 when port side is higher than starboard side by five degrees.

TRIM ANGLE

Compensate for fore-aft inclination of the transducer face. Set [+] angle for fore-high state and [-] angle for aft-high state. (-12.8 to 12.7 (°))

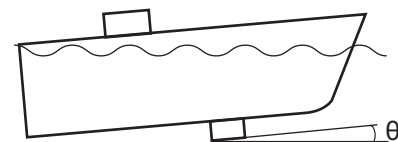

Set to +5.0 when port side is higher than starboard side by five degrees.

GT SPD CALIB

Calibrate ship's speed in the ground tracking mode. (setting range: -12.8 to 2.7 (%)) True speed should be calculated at the sea trial. Calibration value is obtained as follows:

$$\text{Calibration value (\%)} = \frac{\text{True speed} - (\text{CI-68-measured speed})}{\text{True speed}} \times 100$$

4. ADJUSTMENTS

WT SPD CALIB

Calibrate ship's speed in the water tracking mode. In general, enter the same value as the [GT SPD CALIB]. (-12.8 to 12.7 (%))

BEARING CALIB

Calibrate bearing offset angle of the transducer. When the transducer's fore-aft axis is deviated to starboard from the ship's fore-aft line, set a positive angle. (-30 to 30 (°))

COURSE CALIB

Calibrate course here when the course value in ground tracking mode is different from the external GPS navigator reading though [BEARING CALIB] on the previous page is done correctly. The setting range is -30 to 30 °. The [GT] and [NAV] values next to [COURSE CALIB] show the calibrations of [CSE CALIB MODE] in below.

CSE CALIB MODE

Choose tracking mode to use to calibrate course so that it is the same on both the current indicator and GPS navigator.

[GT]: Enter suitable value so ship's track in the ground tracking mode is the same as that on the NAV mode.

[NAV]: Assuming that the tide near own ship is constant, offset it so tide in fore-aft direction is constant for ten minutes.

[MANUAL]: The course manually entered at [NAV] in [COURSE CALIB].

CSE CALIB EXEC

Calibrate course. Choose [GT] or [NAV] from [CSE CALIB MODE] and then choose [YES] here.

When ground tracking is obtainable (Depth is approx. 3 to 300 m)

1. Press the **TRACK MODE** key to choose the ground tracking mode.
2. In the [CALIB] sub menu, to press ▲ or ▼ to choose [CSE CALIB MODE].
3. Press ◀ to choose [GT].
4. Run the vessel at a speed of about 10 kn, keeping heading constant. To minimize gyro speed error, it is desirable to turn along parallels; namely, eastward or westward.
5. Press ▼ to choose [COURSE CALIB EXEC].
6. Press ▶ to choose [YES].
7. Press the **F1** key to start the calibration. As soon as you press the **F1** key, [0.0] on the [COURSE CALIB] line should be shown in reverse video. After you have traveled 2 nm, the display will show the course calibration angle (result of the calibra-

tion) in normal text. (This value is not retained in the memory; it is reset to zero when the power is turned off.)

MENU 1	MENU 2	ALARM	INSTALLATION
			I/O CALIB OTHER
DRAFT	:	0.0m	
HEEL ANGLE	:	0.0°	
TRIM ANGLE	:	0.0°	
GT SPD CALIB	:	0.0%	
WT SPD CALIB	:	0.0%	
BEARING CALIB	:	0.0°	
COURSE CALIB	:	0.0°	(GT: 0.0° NAV: 0.0°)
CSE CALIB MODE	:	GT	NAV MANUAL
CSE CALIB EXEC	:	NO	YES

Reverse video while calibrating

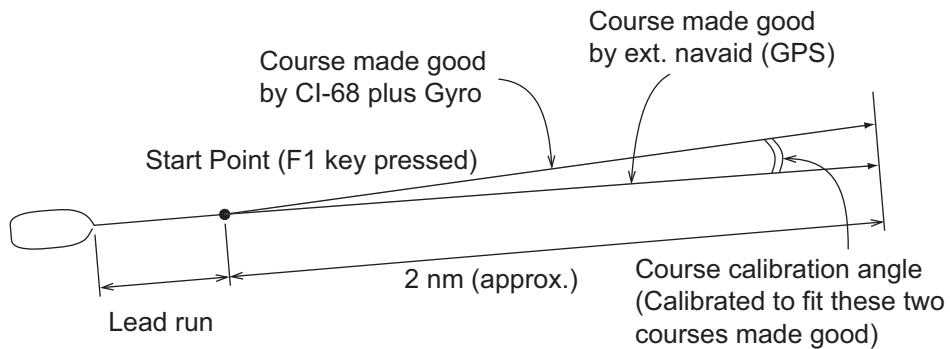

8. Press ▲ to choose [COURSE CALIB].
9. Press ◀ or ▶ to enter the value.
10. Press ▼ to choose [CSE CALIB MODE], and then press ▶ to choose [MANUAL]. The input value for [COURSE CALIB] is only effective when [MANUAL] is selected on the menu.

When ground tracking is not obtainable (Depth is more than 300 m)

1. Press the **TRACK MODE** key to choose the ground tracking mode.
2. In the [CALIB] sub menu, to press ▲ or ▼ to choose [CSE CALIB MODE].
3. Press ◀ or ▶ to choose [NAV].
4. Run the vessel at a speed of about 10 kn for five minutes, keeping heading constant, then return to the starting point.
5. Press ▲ or ▼ to choose [COURSE CALIB EXEC].
6. Press ▶ to choose [YES].
7. Press the **F1** key to start the calibration. As soon as you press the **F1** key, [0.0] on the [COURSE CALIB] line should be shown in reverse video. In about ten minutes (when the calibration is finished), the course calibration angle appears. (This

4. ADJUSTMENTS

value is not retained in the memory; it is reset to zero when the power is turned off.)

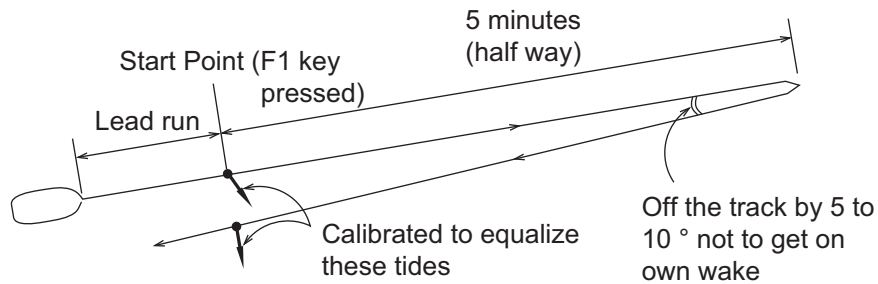

8. Press ▲ to choose [COURSE CALIB].
9. Press ◀ or ▶ to enter the value.
10. Press ▼ to choose [CSE CALIB MODE], and then press ▶ to choose [MANUAL].
The input value for [COURSE CALIB] is only effective when [MANUAL] is selected on the menu.

SOUND VELOCITY

Choose [YES] to calibrate sound velocity.

EXTERNAL KP1, EXTERNAL KP2

Set distance between transducer of this current indicator and external KP transducer which is connected to the current indicator as an interference source. The setting range is 0.0 - 25.5 (m). Also, set the DIP switch as shown "DIP switch settings" on page 4-11.

4.1.3 [OTHER] sub menu

MENU 1	MENU2	ALARM	INSTALLATION			
			I/O	CALIB	OTHER	
DEPTH SOURCE :	<input type="text" value="INTERNAL"/>	EXTERNAL				
BTM TRACK BEAM :	<input type="text" value="B1"/>	B2	B3	ALL		
PULSE LENGTH :	<input type="text" value="NORMAL"/>	LONG				
PWR REDUCTION :	<input type="text" value="OFF"/>	ON				
DEPTH UNIT :	<input type="text" value="m"/>	HR				
TEMP UNIT :	<input type="text" value="°C"/>	°F				
PULSE UNIT :	<input type="text" value="/nm"/>	/km				
CUR FLOW DIR :	<input type="text" value="TO"/>	FROM				
BEAM TEST :	<input type="text" value="OFF"/>					
LANGUAGE* :	JAPANESE	<input type="text" value="ENGLISH"/>	中文	INDONESIA		
SIMULATION :	<input type="text" value="OFF"/>	VARIABLE	FIXED			
RESET SETTINGS :	<input type="text" value="NO"/>	YES				

* Type A: JAPANESE, ENGLISH, 中文, INDONESIA

Type B: JAPANESE, ENGLISH, VIETNAM,

[OTHER] sub menu

DEPTH SOURCE

Choose source of depth data, internal or external.

BTM TRACK BEAM

Choose sounding beam to use to detect bottom. The choices are [B1] (Beam 1), [B2], [B3] and [ALL].

PULSE LENGTH

Choose pulse length to use in the water tracking mode. The choices are [NORMAL] and [LONG].

PWR REDUCTION

Choose [LOW] to reduce output power.

DEPTH UNIT

Choose unit of depth measurement from m or HR.

TEMP UNIT

Choose unit of temperature measurement from °C or °F.

PULSE UNIT

Choose unit of distance measurement from nm or km.

CUR FLOW DIR

Choose how to display tide data. [FROM] shows the direction from which the current is flowing. [TO] shows the direction the current is heading.

BEAM TEST

Choose the beam to test among beam 1, beam 1-2, beam 1-3 and beam 2-3. Press ◀ or ▶ to choose the beam to test. "NOW TESTING BEAM XX*" (*: XX = beam number being tested) appears when a beam is being tested.

LANGUAGE

Choose the interface language.

Type A: JAPANESE, ENGLISH, 中文, INDONESIA

Type B: JAPANESE, ENGLISH, VIETNAME, 越語

SIMULATION

Turn the simulation mode on or off and choose simulation mode parameters.

[OFF]: Disable the simulation mode.

[VARIABLE]: Feeds simulation mode data from the processor to the control unit.

[FIXED]: Use the user-set speed and tide values.

When you choose [VARIABLE] or [FIXED], the message "PRESS FUNCTION KEY TO EXECUTE." appears. Press the **F1** key to start the simulation mode. For [FIXED] selection, the window to set ship's speed, tide speed (layer 1 to layer 5) and tide direction appears (▲, ▼: set a value, ▶: move a digit). And then press the **MENU** key to finish the setting. The message "LOADING THE SIMULATION DATA" appears during the simulation mode.

4. ADJUSTMENTS

RESET SETTINGS

Restore all (except LANGUAGE) default menu settings. Choose [YES] and then press the **F1** key to reset settings. Three beeps sounds when all settings have been reset.

4.2 Input/Output Data

4.2.1 NMEA Input Sentences

NMEA Input Sentences

Talker	Format	Information
**	ZDA	Time (UTC), Date
GP	RMC	GPS ship's speed, Bearing, Own ship's position
LC	RMA	LC ship's speed, Bearing, Own ship's position, Time difference
**	GGA	Own ship's position (L/L), Ship's speed
GP, LC	GLL	Own ship's position (L/L)
GP, LC	VTG	SOG, True course
**	HDT	Heading (True)
**	HDM	Heading (Magnetic)
**	HDG	Heading (Magnetic)
**	DBT	Depth (below the transducer, Ver 1.5)
**	DPT	Depth (Ver 2.0)
**	MTW	Water temperature

** : Not specified.

Priority

- Own ship's position (L/L): GGA>RMC>RMA>GLL
- Ship's speed: VTG>RMC>RMA
- Heading: HDT>HDG>HDM
- Depth: DPT>DBT

4.2.2 NMEA Output Sentences

NMEA Output Sentences

Talker	Format	Information	Interval
VD	VBW	STW, SOG	1 s
VD	VDR	Current direction/speed	3 s
VD	VHW	STW, Heading	1 s
VD	VTG	SOG, Course (True)	1 s
VD	VLW	Trip distance	3 s
VD	CUR	Multiple-layered current	3 s

NMEA output sentences are changeable as below depending on the [NMEA VERSION] setting on the [I/O] sub menu. See "NMEA VERSION" on page 4-1.

NMEA Ver. 1.5: VDR, VHW, VTG, VLW (Trip distance in water tracking mode only)
NMEA Ver. 2.0: VBW, VDR, VHW, VTG, VLW (Trip distance in water tracking mode)

only)

NMEA Ver. 3.0: VBW, VDR, VHW, VTG, VLW, CUR

IEC 61162-1 Ed 2: VBW, VDR, VHW, VTG, VLW (Trip distance in water tracking mode only)

4.2.3 CIF Input/output sentences

Input sentences

Data No.	Information
11	System Time
24、 28	Positioning data (L/L)
44、 48	Ship's speed bearing data
57	Depth data
58	Water temperature data

Priority

Information	Priority (No.)
Positioning data	28>24
Ship's speed bearing data	48>44

Output sentences

Data No.	Information	Interval
56	Single-layered current data	3 s
66	Current indicator-measured speed/bearing	3 s
76	Multiple-layered current (by depth)	15 s

4.3 External Noise and Interference Check

4.3.1 External noise check

Noise level can be measured (without transmission) at the [GENERAL] on the [TEST].

Preparation

1. Press the **MENU** key.
2. Press **▲** to move the cursor to the top of the screen.
3. Press **◀** several times to select [MENU 1].
4. Press **▼** to move the cursor on the sub menu items, and then press **▶** to choose [MENU 4].
5. Press **▼** several times to select [TEST], and press **▶** to choose [GENERAL].
6. Press the **F1** key. If the NL is -5 or more, the unit is receiving affects of interference. In this case, check the following points.
 - Grounding of the transducer unit

4. ADJUSTMENTS

- Noise source around the transceiver unit
- Distance between the transducer cable and ship's power line.

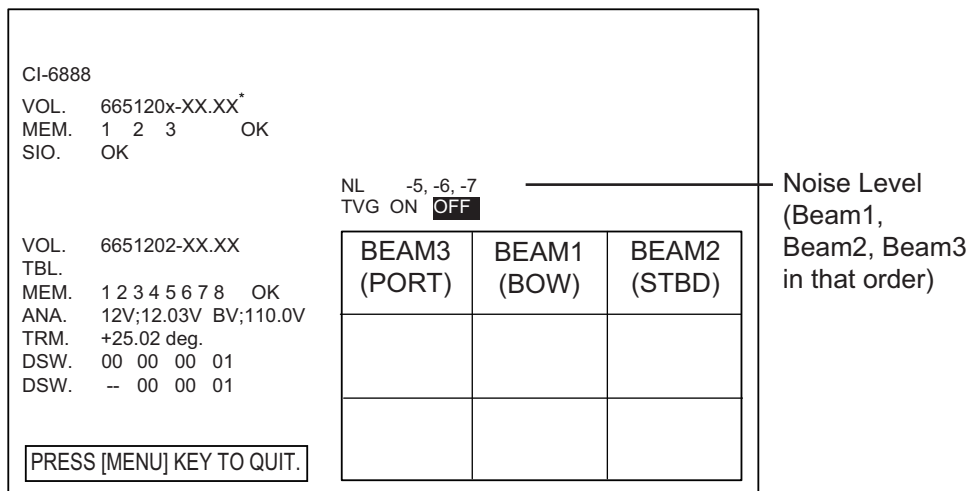

* Type A: 6651203-XX.XX
 JAPANESE, ENGLISH, 中文, INDONESIA

Type B: 6651204-XX.XX
 JAPANESE, ENGLISH, VIETNAM, 越語

XX: Program Version No.

Self test ([GENERAL])

4.3.2 Suppressing interference

Input

Up to two interfering equipment can be connected to the interference rejection circuit in the transceiver unit via EX KP IN 1 or EX KP IN 2 port. This circuit receives the keying pulse (KP) from the interfering equipment to reject interference.

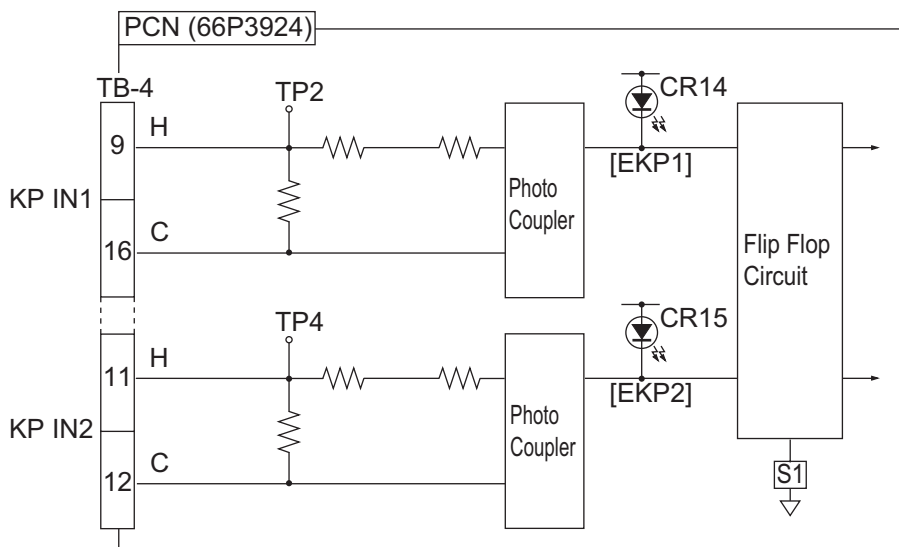

Interference rejection circuit

Check of keying pulse

The following keying pulse is required from the interfering equipment. If the level is out of the ratings or KP output circuit is not provided, take the measures shown on the next two pages to prevent equipment malfunction.

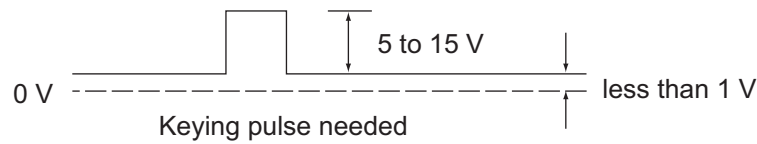

If the level is out of the ratings or KP output circuit is not provided, take the measures shown on the next two pages to prevent equipment malfunction.

Buffer circuit for positive-going KP

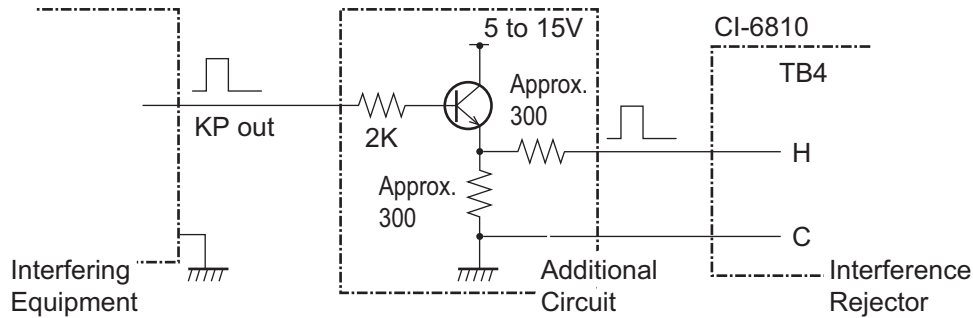

Buffer circuit for negative-going KP

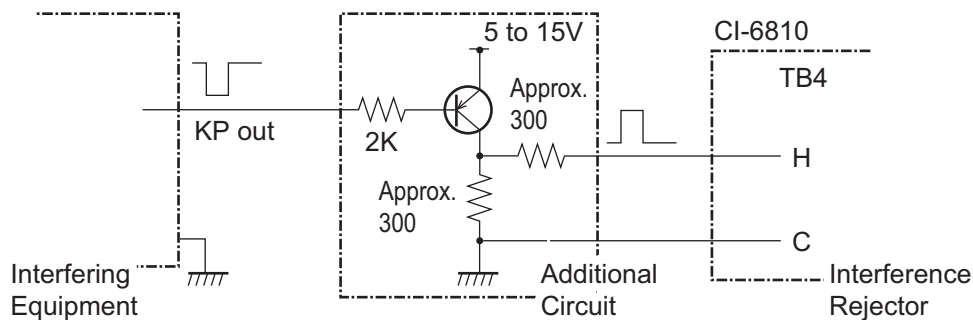

The following method also is available.

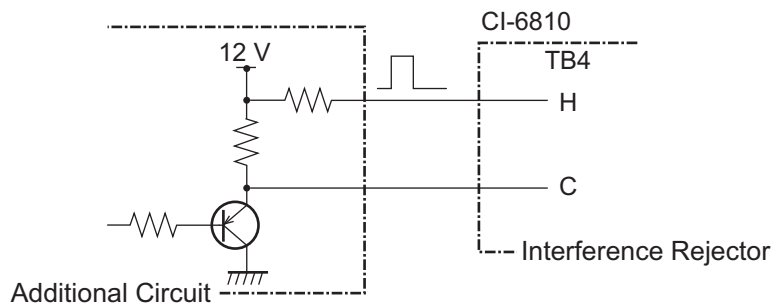

Buffer circuit for keying pulse (KP)

DIP switch settings

When KP signal is input to KP IN1, set the switch S1-#3 on the PCN Board 66P3924 to ON. KP signal is positive logic: Set the switch S1-#1 on the PCN Board to OFF. KP signal is negative logic: Set the switch S1-#1 on the PCN Board to ON

When KP signal is input to KP IN2, set the switch S1-#4 on the PCN Board 66P3924. KP signal is positive logic: Set the switch S1-#2 on the PCN Board to OFF. KP signal is negative logic: Set the switch S1-#2 on the PCN Board to ON

4. ADJUSTMENTS

Output

When outputting keying pulse to suppress interference to other ultrasound equipment, take the TX trigger pulse from TB4 (KP OUT), which is the KP terminal for external output.

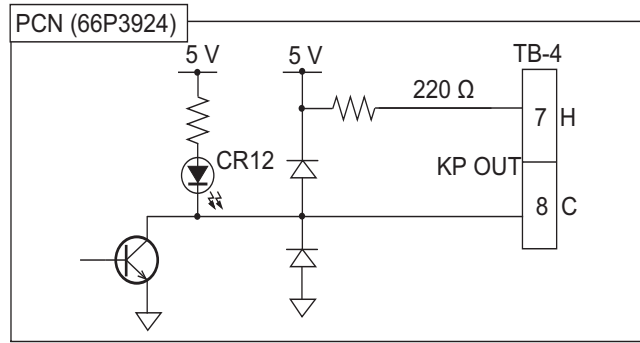

4.4 Setting Output Data

You can select data output from TB2-#1 and #2 on the terminal board by the setting on the PCN Board 66P3924.

Type

Select RS-422 (default setting) or RS-232C by setting the DIP switch J5 and J6 on the PCN Board 66P3924.

Data

Select the output data among NMEA, CIF, Current data and Display data. Use the jumper block J8 on the PCN Board 66P3924.

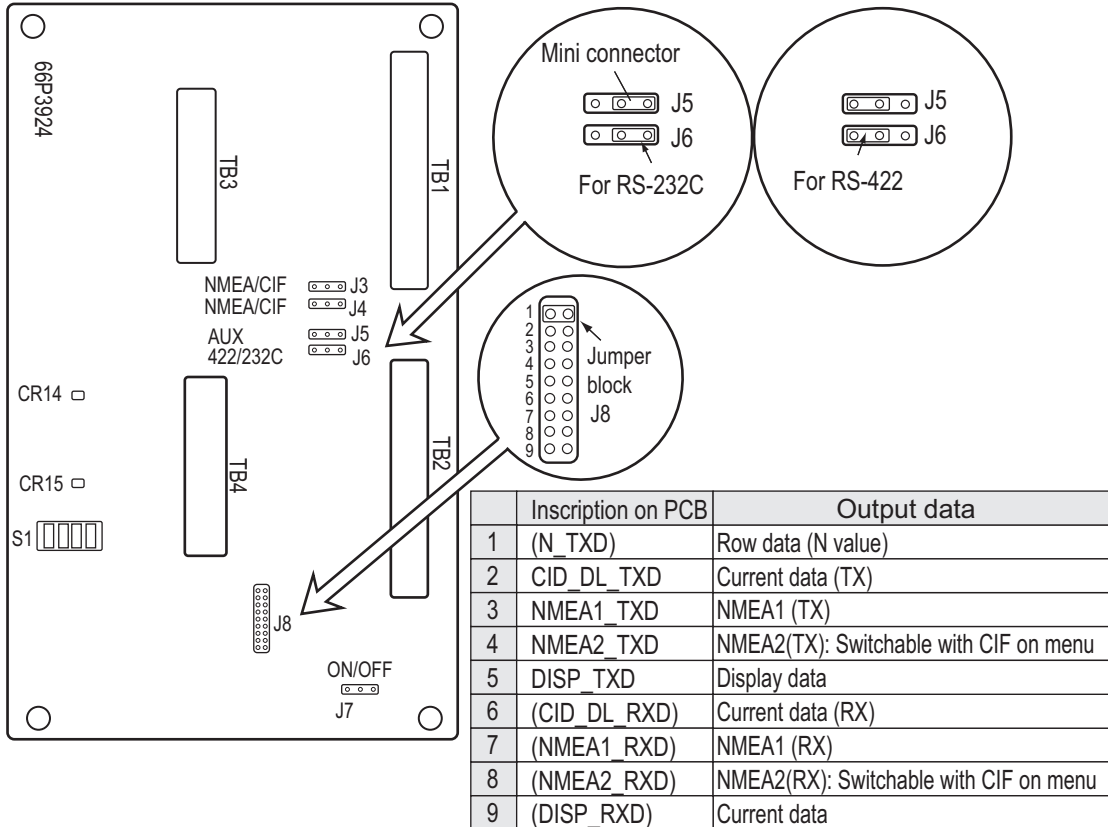

4.5 DIP Switch Setting

4.5.1 Tide calculation response

If the tide calculation response is too slow, set the DIP switch S1 on the PON Board 66P3924 appropriately.

DIP #	Function	Default Setting	OFF	ON
5	Minute constant selection (current response time for NAV mode)	OFF	Normal (Normal setting. Minute constant: 0.05 kn)	Slow (When current speed is slow and unstable. Minute constant: 0.01 kn)
6	Smoothing filter	OFF	YES	NO
7	Bearing addition	OFF	Adds bearing information before averaging the ship's speed.	Adds bearing information after averaging the ship's speed.

4.5.2 Speed output interval

Select the output interval of ship's speed display.

DIP #	Function	Default Setting	OFF	ON
8	Select output interval of ship's speed.	OFF	3 sec	1 sec

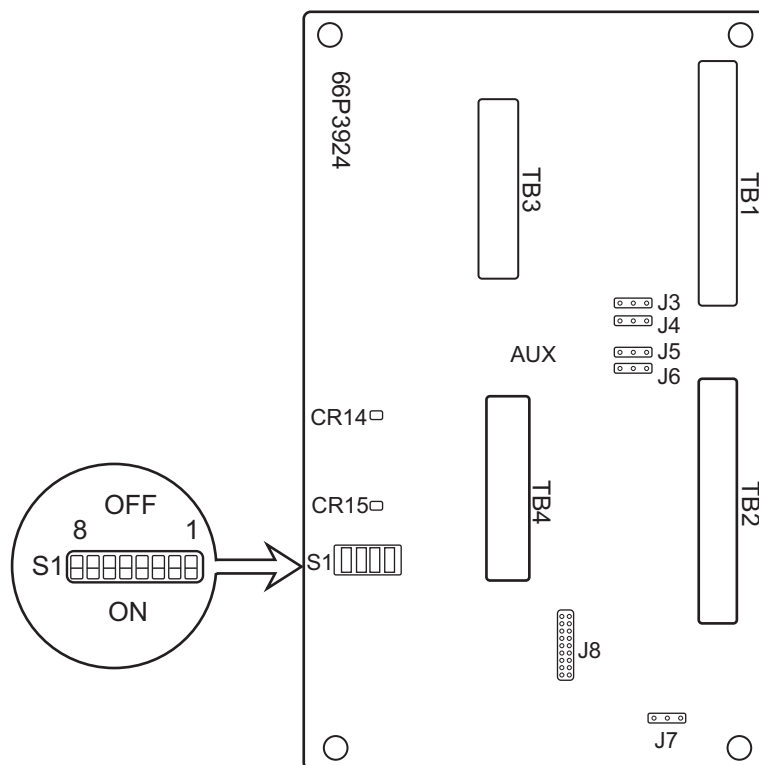

PON Board 66P3924

4.6 Sea Trial Check

4.6.1 Ship's speed test

Do the milepost test where ground tracking measurement can be done.

1. Reset the distance run at the moment the milepost test is initiated.
2. Read the distance run at the moment the milepost test is initiated.
3. Calculate true ship's speed (1) from the data of the milepost test and ship's speed of the CI-68 from that of the distance run (2).
4. If the error between (1) and (2) is more than $\pm (1\%+0.1 \text{ kn})$, correct it referring to the [GT SPD CALIB] on page 4-3. Calibrating is not necessary when the error is within $\pm (1\%+0.1 \text{ kn})$.
5. Repeat the milepost test several times. Record the data in Table 1.
6. Record the ship's speed every 10 seconds in table 2.
7. Calculate the average ship's speed from the data in the Table 2 to compute accuracy.

4.6.2 Current data check

Use the ground tracking mode to record the current (tide) data.

1. Run your boat following the square course shown below. Each side of the square is about 1 mile in length.
2. Record the ship's speed and tide data every 30 seconds in table 3.

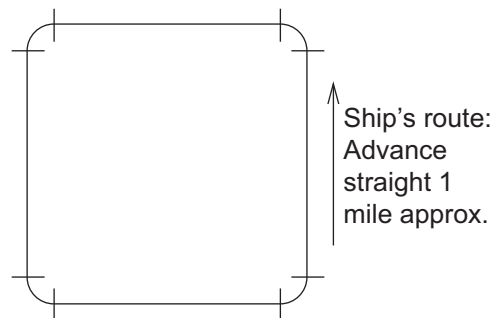

3. On a separate piece of paper, plot the current speed and direction based on the table 3. Confirm that the current reading is stable in any ship's heading. (Only when the current changes minimally while the ship runs square course.)

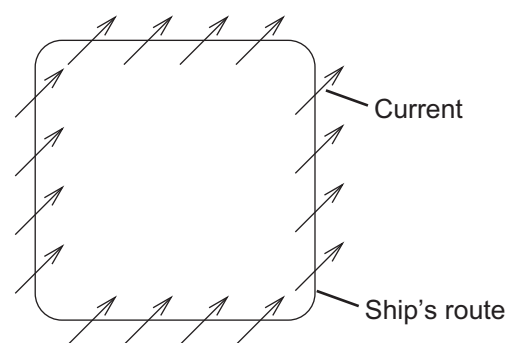

Confirm that the currents orient the same direction. If not, the interference from other equipment, air bubbles and noise may be present. Also, take into account that interference from air bubbles may occur since there is no load in the milepost test.

Note: When a bearing sensor is connected in lieu of a gyrocompass, accurate measurement of current direction is not expected because the bearing data itself is in error. Note that it is difficult to distinguish this unit reading when the above test is done where the current is complex.

Table 1: Ship's Speed Test

TEST SITE _____ CAPTAIN _____ DRAFT Fore _____ Aft _____ Mean _____ (m)
 SHIP'S NAME _____ SHIP NUMBER _____ SHIP YARD _____ SHIP'S LENGTH _____ (m)

DATE	TIME	ENGINE		MILEPOST*1 (kn)	SPEED (kn)	Current Indicator		EM-LOG (kn)	DEPTH (m)	COURSE (Deg)	WIND (m/s)	SEA COND.	CURRENT (kn)	Remarks
		OUTPUT	RPM			DIST *3 (kn)	TIME (s)							
AVG.														
AVG.														
AVG.														
AVG.														
AVG.														
AVG.														
AVG.														

*1 : Milepost _____ miles *2 : Error = $\frac{\text{Speed measured by milepost} - \text{Current Indicator Speed}}{\text{Speed measured by milepost}} \times 100 (\%)$

*3 : Current Indicator Speed = $\frac{\text{Mile (Milepost)}}{\text{Time (sec)}} \times 3600$

Measuring Mode
GROUND
WATER

4. ADJUSTMENTS

Table 2: Ship's Speed Test



TIME	SPD (kn)	Remarks	TIME	SPD (kn)	Remarks
00			00		
10		SHIP NUMBER _____	10		SHIP NUMBER _____
20		DEPTH _____ (m)	20		DEPTH _____ (m)
30		TEST SITE _____	30		TEST SITE _____
40		WIND SPEED	40		WIND SPEED
50			50		
00			00		
10			10		
20		COURSE _____ (ms)	20		COURSE _____ (ms)
30			30		
40			40		
50			50		
00			00		
10			10		
20			20		
30			30		
40			40		
50			50		
00			00		
10			10		
20			20		
30			30		
40			40		
50			50		
00			00		
10			10		
20			20		
30			30		
10			40		
50			50		
00			00		

Table 3: Current Display Behaviour Test

SHIP'S NAME _____ SHIP'S TYPE _____ Load _____ TEST DATE _____ TEST SITE _____

No.	TIME	SHIP'S HDG. (DEG.)	SHIP'S SPD		LAYER 1			LAYER 2			LAYER 3			LAYER 4			LAYER 5			WIND (REL)		Remarks	
			(kn)	FORE/AFT/LEFT/RIGHT (kn)	SPD (kn)	DIR	DEPTH (m)	SPD (kn)	DIR	DEPTH (m)	SPD (kn)	DIR	DEPTH (m)	SPD (kn)	DIR	DEPTH (m)	SPD (kn)	DIR	DEPTH (m)	SPD (m/s)	DIR (DEG.)		
1																							
2																							
3																							
4																							
5																							
6																							
7																							
8																							
9																							
10																							
1																							
2																							
3																							
4																							
5																							
6																							
7																							
8																							

Measuring mode _____ GROUND / WATER



Depth LAYER 1 _____ (m)

LAYER 2 _____ (m)

LAYER 3 _____ (m)

SIGN _____

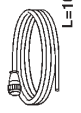
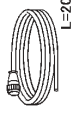
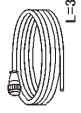
CODE NO.	66AS-X-9405-1	66AS-X-9405-1
TYPE		1/1

工事材料表		CI-68/88			
番号	名称	略図	型名/規格	数量	用途/備考
NO.	NAME	OUTLINE	DESCRIPTIONS	QTY	REMARKS
1	ケーブル組品 CABLE ASSEMBLY	 L=10M	66S1238 *10M* CODE NO. 0017-240-580-00	1	選択 TO BE SELECTED. 操作部-送受信演算部 UNIT-TRANSCEIVER UNIT
2	ケーブル組品 CABLE ASSEMBLY	 L=20M	66S1238 *20M* CODE NO. 0017-240-570-00	1	選択 TO BE SELECTED. 操作部-送受信演算部 UNIT-TRANSCEIVER UNIT
3	ケーブル組品 CABLE ASSEMBLY	 L=30M	66S1238 *30M* CODE NO. 0017-240-580-00	1	選択 TO BE SELECTED. 操作部-送受信演算部 UNIT-TRANSCEIVER UNIT
4	ケーブル組品 CABLE ASSY.	 L=50M	66S1238 *50M* CODE NO. 0017-240-580-00	1	選択 TO BE SELECTED. 操作部-送受信演算部 UNIT-TRANSCEIVER UNIT

型式/コード番号が2段の場合、下段より上段に代わる増設部品であり、どちらかが入っています。なお、品質は変わりません。
TWO TYPES AND CODES MAY BE LISTED FOR AN ITEM. THE LOWER PRODUCT MAY BE SHIPPED IN PLACE OF THE UPPER PRODUCT. QUALITY IS THE SAME.
(略図の寸法は、参考値です。 DIMENSIONS IN DRAWING FOR REFERENCE ONLY.)

CODE NO.	006-917-660-00	66AS-X-9401-2
TYPE	CF66-01501	1/1

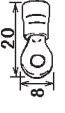
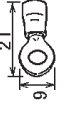
工事材料表					
番号	名称	略図	型名/規格	数量	用途/備考
NO.	NAME	OUTLINE	DESCRIPTIONS	QTY	REMARKS
1	圧着端子 CRIMP-ON LUG		FV1-25-4(LF) FV1-25-4 CODE NO. 000-166-666-10 000-538-114-30	10	
2	圧着端子 CRIMP-ON LUG		FV2-4 FV2-4 7 CODE NO. 000-157-247-10 000-538-116-30	5	

型式/コード番号が2段の場合、下段より上段に代わる増設部品であり、どちらかが入っています。なお、品質は変わりません。
TWO TYPES AND CODES MAY BE LISTED FOR AN ITEM. THE LOWER PRODUCT MAY BE SHIPPED IN PLACE OF THE UPPER PRODUCT. QUALITY IS THE SAME.
(略図の寸法は、参考値です。 DIMENSIONS IN DRAWING FOR REFERENCE ONLY.)

FURUNO

CODE NO.	006-916-750-00	66AS-X-9402 -5	1/1
TYPE	CP66-01503		

工事材料表

INSTALLATION MATERIALS

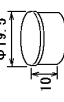
番号 NO.	名称 NAME	略図 OUTLINE	型名/規格 DESCRIPTIONS	数量 QTY	用途/備考 REMARKS
1	ケーブル組立 CABLE ASSEMBLY	 L=0.3M	66S123B-2 CODE NO. 000-143-492-1/2 *0.3M*	1	
2	防水キャップ WATERPROOF CAP	 Φ19.5 10	MF-A10C CODE NO. 000-154-639-1/0	1	

(略図の寸法は、参考値です。 DIMENSIONS IN DRAWING FOR REFERENCE ONLY.)

FURUNO ELECTRIC CO., LTD.

C7252-M02-E

FURUNO

CODE NO.	006-917-350-00	66AS-X-9404 -3	1/1
TYPE	CP66-01504		

工事材料表

INSTALLATION MATERIALS

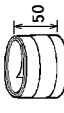
番号 NO.	名称 NAME	略図 OUTLINE	型名/規格 DESCRIPTIONS	数量 QTY	用途/備考 REMARKS
1	圧着端子 CRIMP-ON LUG	 23 7 11	FV5.5-S4 (LF) FV5.5-S4 000-166-750-10 CODE NO. 000-538-121-30	4	
2	7-ス極 COPPER STRAP	 50 L=1.2m	WEA-1004-0 R0HS WEA-1004-0 500-310-040-10 CODE NO. 500-310-040-30	1	

型式/コード番号が2段の場合、下段より上段に代わる標準部品であり、どちらかが入っています。なお、品質は変わりません。
 TWO TYPES AND CODES MAY BE LISTED FOR AN ITEM. THE LOWER PRODUCT MAY BE SHIPPED IN PLACE OF THE UPPER PRODUCT. QUALITY IS THE SAME.





(略図の寸法は、参考値です。 DIMENSIONS IN DRAWING FOR REFERENCE ONLY.)

FURUNO ELECTRIC CO., LTD.

C7252-M04-B

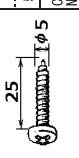
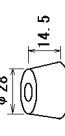
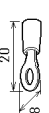
FURUNO

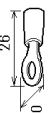
CODE NO. 001-509-920-00 66AL-X-9409-0
 TYPE CP66-02201 1/1





工事材料表		INSTALLATION MATERIALS	
番号 NO.	名称 NAME	略図 OUTLINE	用途/備考 REMARKS
1	圧入端子 TAPPING SCREW		数量 QTY 4
2	ゴムスリーブ RUBBER SLEEVE		数量 QTY 1
3	圧着端子 CRIMP-ON LUG		数量 QTY 18
4	圧着端子 CRIMP-ON LUG		数量 QTY 10
5	圧着端子 CRIMP-ON LUG		数量 QTY 3
6	銅板 COPPER STRAP		数量 QTY 1

(略図の寸法は、参考値です。 DIMENSIONS IN DRAWING FOR REFERENCE ONLY.)

FURUNO ELECTRIC CO., LTD.

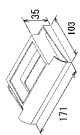
FURUNO

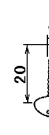
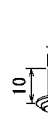
CODE NO. 001-413-590-00 02FJ-X-9508-3
 TYPE FP02-05101 1/1

付属品表		ACCESSORIES	
番号 NO.	名称 NAME	略図 OUTLINE	用途/備考 REMARKS
1	取り付け台 MOUNTING BASE		数量 QTY 1
2	ブラケット BRACKET		数量 QTY 1
3	セルフタッピングネジ SELF-TAPPING SCREW		数量 QTY 4
4	ワッシャー WASHER BINDING HEAD SCREW		数量 QTY 4
5	六角ボルト HEX. BOLT		数量 QTY 2

型式/コード番号が2段の場合、下段より上段に代わる部品であり、どちらが入っています。なお、品質は変わりません。
 TWO TYPES AND CODES MAY BE LISTED FOR AN ITEM. THE LOWER PRODUCT MAY BE SHIPPED IN PLACE OF THE UPPER PRODUCT. QUALITY IS THE SAME.
 (略図の寸法は、参考値です。 DIMENSIONS IN DRAWING FOR REFERENCE ONLY.)

FURUNO ELECTRIC CO., LTD.

FURUNO

CODE NO.	006-556-240	06AS-X-9503 -3	1/1
TYPE	FP06-01102		

付属品表

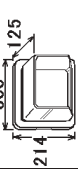
ACCESSORIES				
番号 NO.	名称 NAME	略図 OUTLINE	数量 QTY	用途/備考 REMARKS
1	フード 及び HOOD ASSY.		1	
			CODE NO.	006-556-240

(略図の寸法は、参考値です。)
FURUNO ELECTRIC CO., LTD.
DIMENSIONS IN DRAWING FOR REFERENCE ONLY.)

FURUNO

CODE NO.	006-916-680-00	66AS-X-9501 -3	1/1
TYPE	FP66-00601		

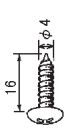
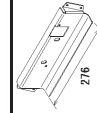
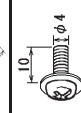

付属品表

ACCESSORIES				
番号 NO.	名称 NAME	略図 OUTLINE	数量 QTY	用途/備考 REMARKS
1	+self-tapping screw 1/2 SELF TAPPING SCREW		4	
			CODE NO.	000-162-609-10
2	ブラケット BRACKET		1	
			CODE NO.	100-307-800-10
3	+self-tapping screw BINDER HEAD SCREW-F		2	
			CODE NO.	000-163-548-10

型式/コード番号が2版の場合、下段より上段に代わる関連部品であり、どちらかが入っています。なお、品質は変わりません。
TWO TYPES AND CODES MAY BE LISTED FOR AN ITEM. THE LOWER PRODUCT MAY BE SHIPPED IN PLACE OF THE UPPER PRODUCT.
QUALITY IS THE SAME.
(略図の寸法は、参考値です。)
DIMENSIONS IN DRAWING FOR REFERENCE ONLY.)

A-9

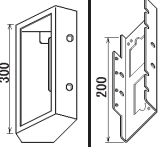
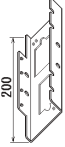
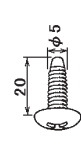
FURUNO

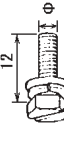
CODE NO.		006-556-260-00		06AS-X-9501-7	
TYPE		FP06-01120		1/1	
番号 NO.	名称 NAME	略図 OUTLINE	型名/規格 DESCRIPTIONS	数量 Q'TY	用途/備考 REMARKS
1	操作取付台 CONTROL UNIT MOUNTING BASE		06-021-2111-1 CODE NO. 006-279-741-10	1	
2	制御ユニットブラケット CONTROL UNIT BRACKET		06-021-2112-0 ROMS CODE NO. 006-281-880-10	1	
3	自己タップネジ SELF-TAPPING SCREW		5X20 SUS304 CODE NO. 000-162-608-10	2	
4	化粧プラグ COSMETIC PLUG		DP-687 7φ CODE NO. 000-165-987-10	2	
5	六角ボルト ヘクスラット HEX BOLT (SLOTTED WASHER HEAD)		M4X12 SUS304 CODE NO. 000-162-939-10	4	

型式/コード番号が2取の場合、下段より上段に代わる油断部品であり、どちらかが入っています。なお、品質は変わりません。
TWO TYPES AND CODES MAY BE LISTED FOR AN ITEM. THE LOWER PRODUCT MAY BE SHIPPED IN PLACE OF THE UPPER PRODUCT. QUALITY IS THE SAME.
(略図の寸法は、参考値です。 DIMENSIONS IN DRAWING FOR REFERENCE ONLY.)

FURUNO ELECTRIC CO., LTD.

C1316-F01-H

A-10

FURUNO

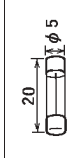
CODE NO.		006-916-730		66AS-X-9301-1 1/1		
TYPE		SF66-00801		BOX NO. P		
SHIP NO.	SPARE PARTS LIST FOR	U S E		SETS PER VESSEL		
ITEM NO.	NAME OF PART	OUTLINE	DWG. NO. OR TYPE NO.	QUANTITY WORKING PER SET	SPARE PER SET	REMARKS/CODE NO.
1	ヒューズ FUSE		FCMB 125V 2A PBF		3	操作部 CONTROL UNIT 000-157-479
MFR'S NAME	FURUNO ELECTRIC CO., LTD.	DWG NO.	C7252-P01-B			
(略図の寸法は、参考値です。 DIMENSIONS IN DRAWING FOR REFERENCE ONLY.)						
					1/1	

FURUNO

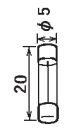
SHIP NO.		SPARE PARTS LIST FOR				U S E		REMARKS/CODE NO.		SETS PER VESSEL	
		CODE NO. 006-556-200		06AS-X-9301-4 1/1		TYPE SP06-01101		BOX NO. P			
ITEM NO.	NAME OF PART	OUTLINE	DWG. NO. OR TYPE NO.	QUANTITY							
				WORKING	SPARE						
				PER SET	PER VES						
1	E _t -X [*] FUSE	 20 ϕ 5	EQMR 125V 3A PBF	1	3						
						000-157-481					
MFR'S NAME		FURUNO ELECTRIC CO., LTD.				DWG NO.		C1316-P01-D		1/1	

(縮図の寸法は、参考値です。 DIMENSIONS IN DRAWING FOR REFERENCE ONLY.)

FURUNO

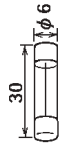
SHIP NO.		SPARE PARTS LIST FOR				U S E		REMARKS/CODE NO.		SETS PER VESSEL	
		CODE NO. 006-917-340		66AS-X-9303-1 1/1		TYPE SP66-00803		BOX NO. P			
ITEM NO.	NAME OF PART	OUTLINE	DWG. NO. OR TYPE NO.	QUANTITY							
				WORKING	SPARE						
				PER SET	PER VES						
1	E _t -X [*] FUSE	 30 ϕ 6	F680 250V 3A PBF F680 3A AC250V		7						
						000-155-841-10					
						000-549-021-00					
MFR'S NAME		FURUNO ELECTRIC CO., LTD.				DWG NO.		C7252-P03-A		1/1	

(縮図の寸法は、参考値です。 DIMENSIONS IN DRAWING FOR REFERENCE ONLY.)

型式/ノド番号が2段の場合、下段より上段に代わる過熱部品であり、どちらかが入っています。なお、品質は変わりません。 TWO TYPES AND CODES MAY BE LISTED FOR AN ITEM. THE LOWER PRODUCT MAY BE SHIPPED IN PLACE OF THE UPPER PRODUCT. QUALITY IS THE SAME.

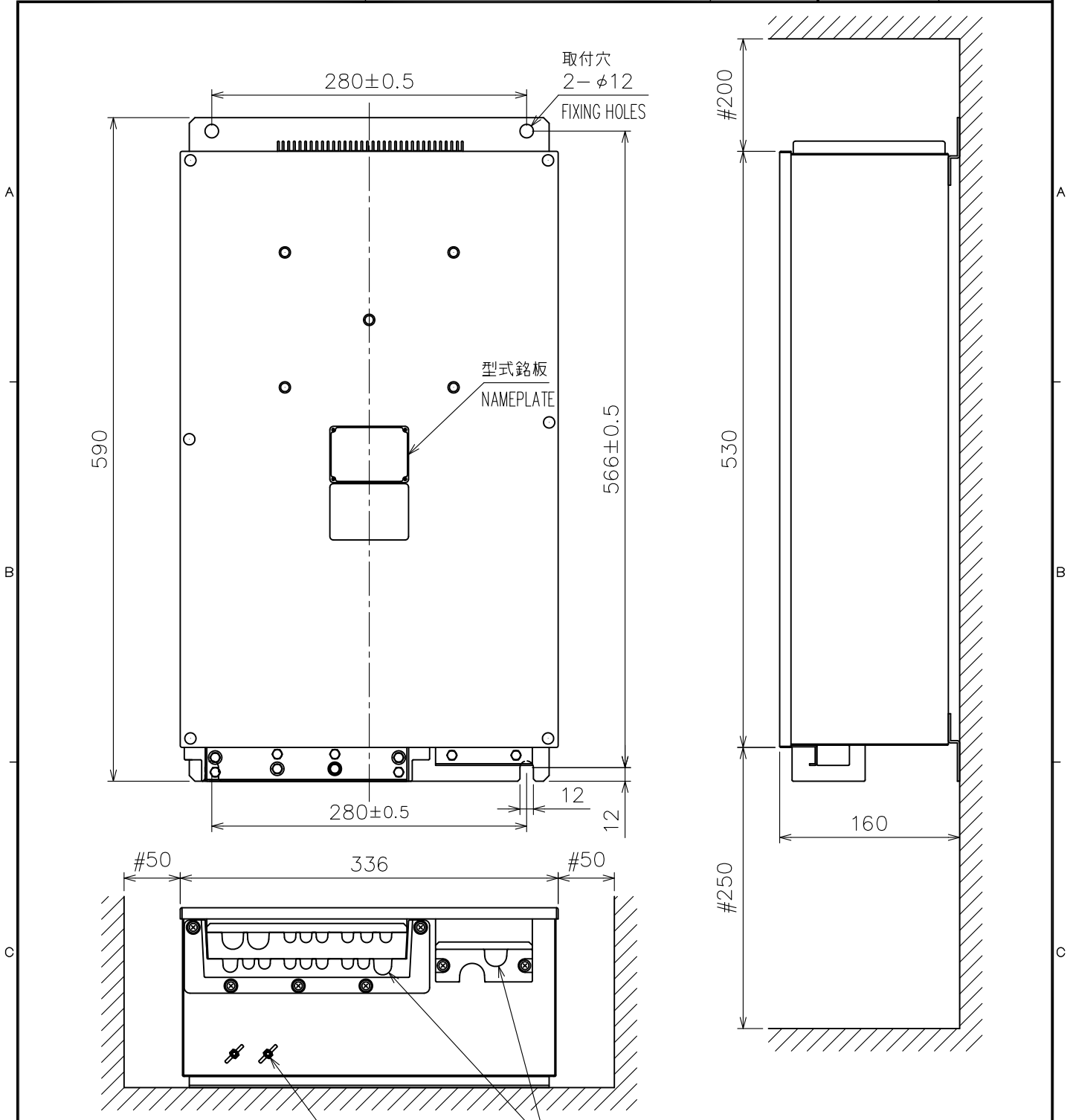

注記

- 1) 指定外の寸法公差は表1による。
- 2) #印寸法は最小サービス空間寸法とする。
- 3) 取付用ネジはM10ボルト、またはコーチボルト呼び径9を使用のこと。

NOTE

1. TABLE 1 INDICATES TOLERANCE OF DIMENSIONS WHICH IS NOT SPECIFIED.
2. #: MINIMUM SERVICE CLEARANCE.
3. USE M10 BOLTS OR COACH SCREWS $\phi 9$ FOR FIXING THE UNIT.

表1 TABLE 1

寸法区分 (mm) DIMENSION	公差 (mm) TOLERANCE
$L \leq 50$	± 1.5
$50 < L \leq 100$	± 2.5
$100 < L \leq 500$	± 3
$500 < L \leq 1000$	± 4

DRAWN 25/Jul/2014 I.YAMASAKI	TITLE CI-6810/3810
CHECKED 25/Jul/2014 H.MAKI	名称 送受信演算部
APPROVED 29/Jul/2014 H.MAKI	外寸図
SCALE 1/5 MASS 17.0 $\pm 10\%$ kg	NAME TRANSCEIVER UNIT
DWG. No. C7252-G03-C	REF. No. 66-030-100G-2
OUTLINE DRAWING	

表 1 TABLE 1

寸法区分 (mm) DIMENSIONS	公差 (mm) TOLERANCE
0 < L ≤ 50	± 1.5
50 < L ≤ 100	± 2.5
100 < L ≤ 500	± 3

5

4

3

2

1

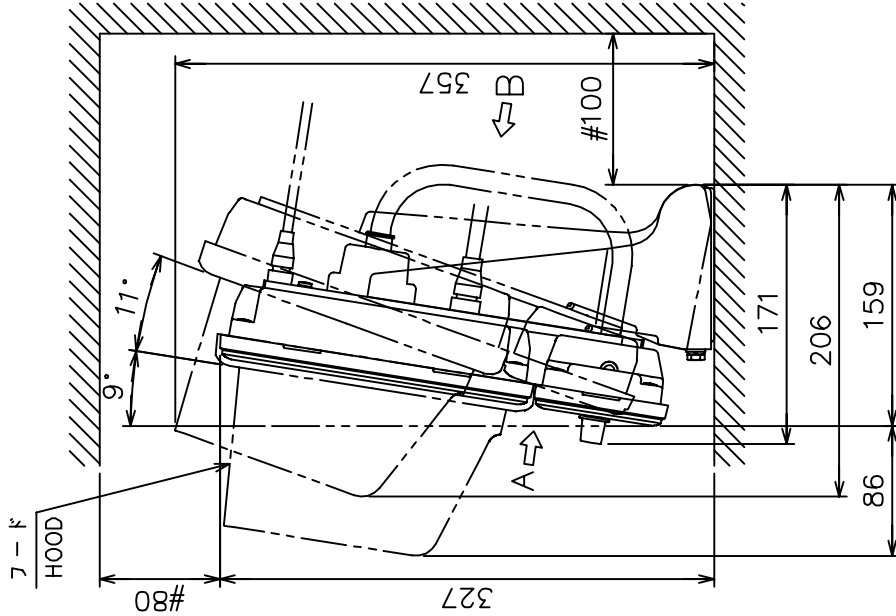
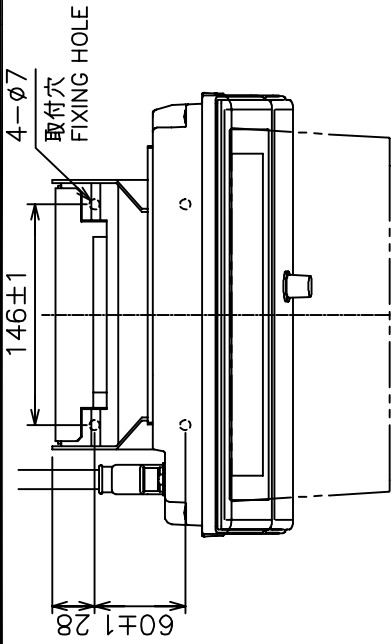

矢視 A
VIEW A

銘板
NAMEPLATE

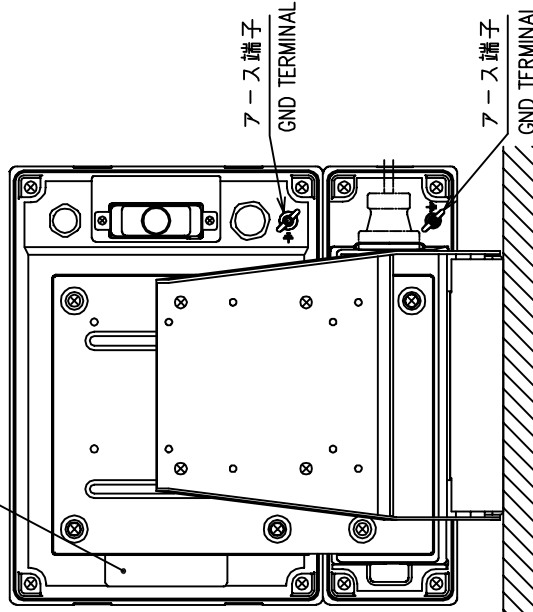

矢視 B
VIEW B

- 注記
- 1) #印寸法は最小サービス空間寸法とする。
 - 2) 指定外の寸法公差は表1による。
 - 3) 取付用ネジは+トラスタックピンネジ呼び径5x20を使用のこと。
 - 4) 装備ケーブルはサービス時、本体を前方に十分引出せるよう余裕を持たせること。

- NOTE
1. # MINIMUM SERVICE CLEARANCE.
 2. TABLE 1 INDICATES TOLERANCE OF DIMENSIONS WHICH IS NOT SPECIFIED.
 3. USE TAPPING SCREWS 5x20 FOR FIXING UNIT.
 4. KEEP ENOUGH CABLE LENGTH BEHIND UNIT.

DRAWN	JULY 22, '04	E. MIYOSHI	TITLE	MU-100C + CI-6888
CHECKED		TAKAHASHI, T	名称	表示部 + 操作部
APPROVED		Y. Hatai	外寸図	
SCALE	1/5	MAS ±10%	NAME	MONITOR UNIT AND CONTROL UNIT
DWG.No.		C7252-G01-B		OUTLINE DRAWING
				66-030-300G-1



表 1 TABLE 1

寸法区分 (mm) DIMENSIONS	公差 (mm) TOLERANCE
0 < L ≤ 50	±1.5
50 < L ≤ 100	±2.5
100 < L ≤ 500	±3

注記 1) #印寸法は最小サービス空間寸法とする。
 2) 指定外の寸法公差は表1による。
 3) 取付用ネジはプラスタッピングピンネジ呼び径5×20を使用のこと。
 4) 装着ケーブルはサービス時、本体を前方に十分引出せるよう余裕を持たせること。

NOTE 1. # MINIMUM SERVICE CLEARANCE.
 2. TABLE 1 INDICATES TOLERANCE OF DIMENSIONS WHICH IS NOT SPECIFIED.
 3. USE SELF-TAPPING SCREWS 5x20 FOR FIXING THE UNIT.
 4. LEAVE ENOUGH SLACK IN CABLING SO UNIT CAN BE DRAWN FORWARD WITHOUT DISCONNECTING CABLING.

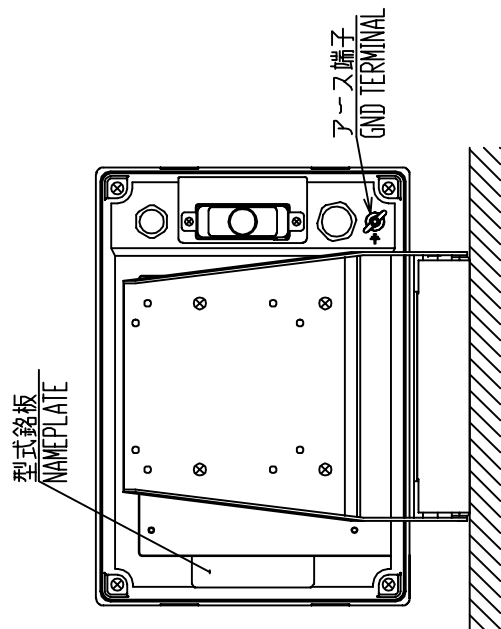
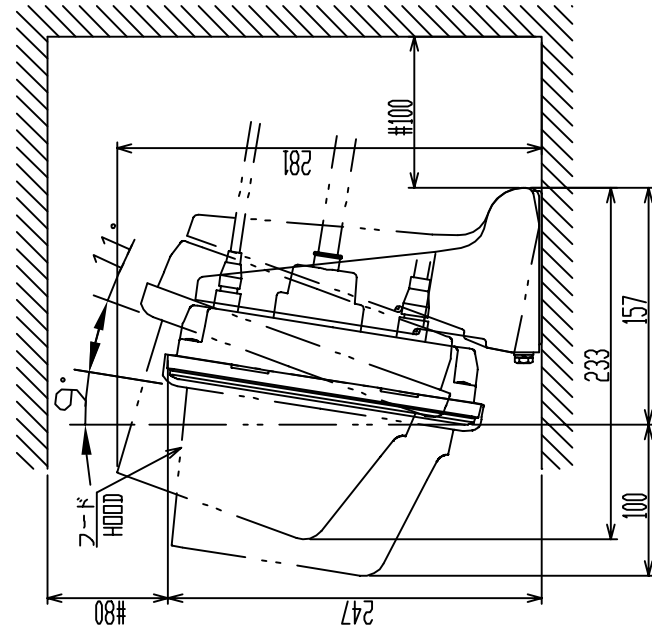
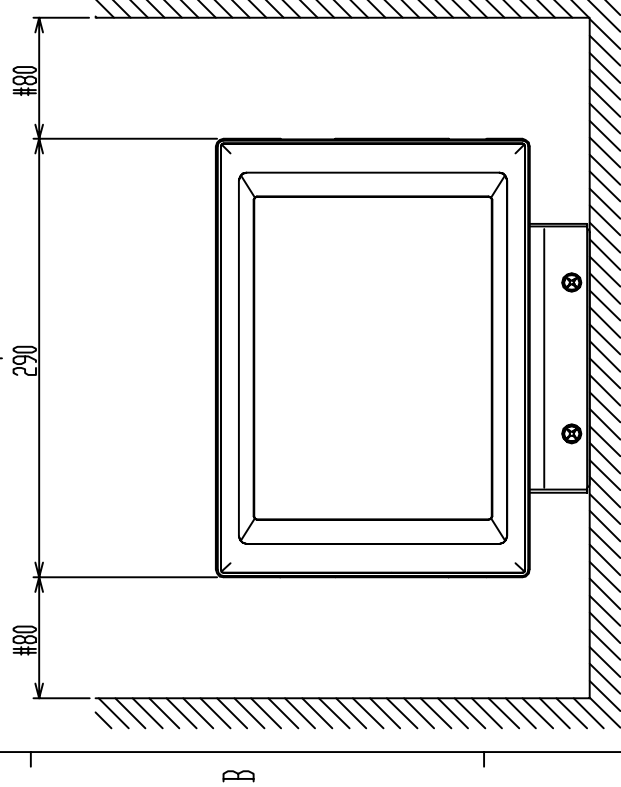
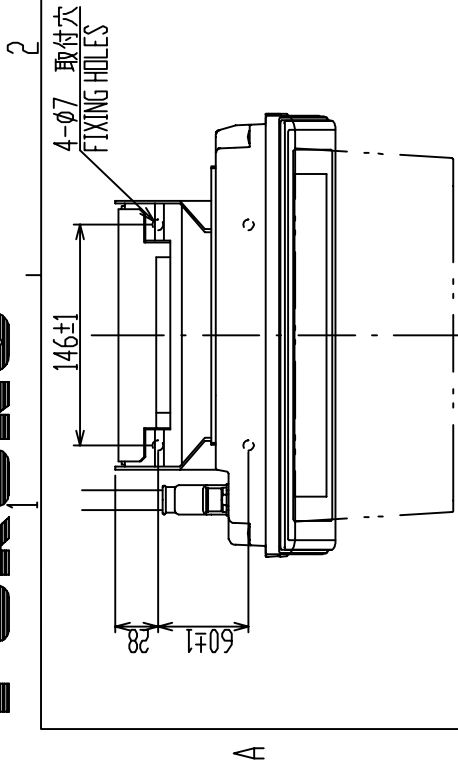
DRAWN	Dec.15, '04	EMITSUSHI	TITLE	MU-100C
CHECKED		TAKAHASHI, I	名称	表示部 (分離型、卓上装備)
APPROVED		Y. Hatai	外寸図	
SCALE	1/5	MASS 4.2 kg	NAME	MONITOR UNIT (SEPARATE, TABLETOP MOUNT)
DWG.No.	C1316-G08-D	06-021-191G-2		OUTLINE DRAWING

表 1. TABLE 1.

寸法区分 (mm) DIMENSION	公差 (mm) TOLERANCE
0 < L ≤ 50	±1.5
50 < L ≤ 100	±2.5
100 < L ≤ 500	±3

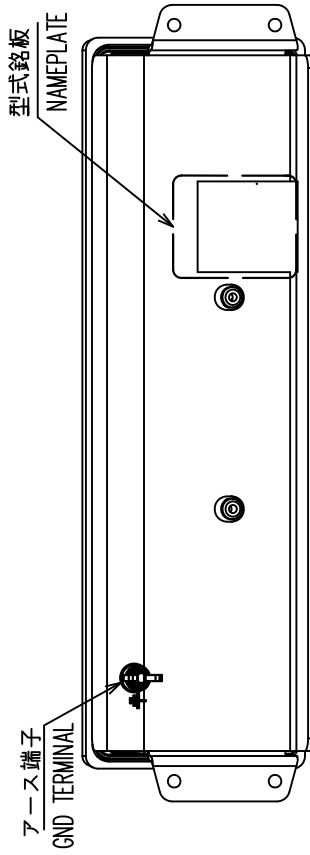
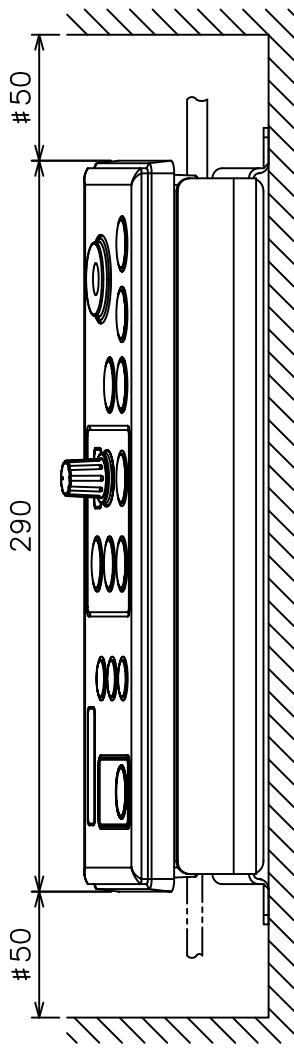
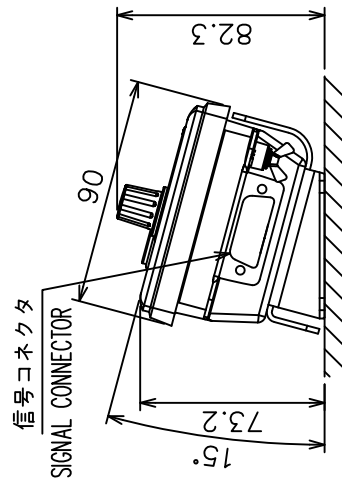
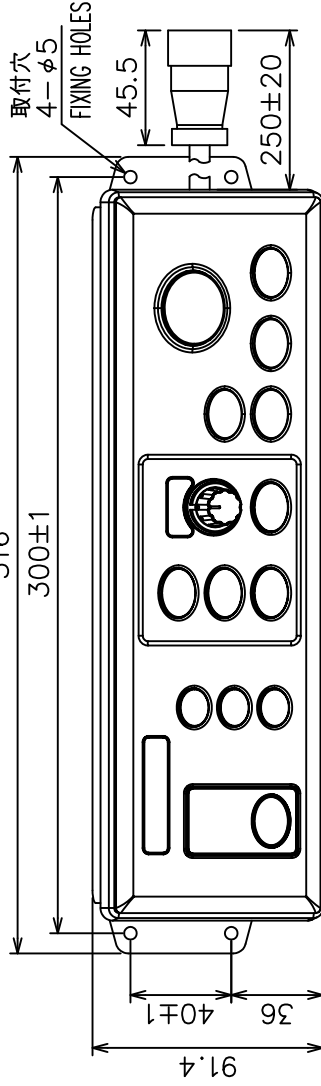

注 記

- 1) 指定外の寸法公差は表 1 による。
- 2) #印寸法は最小サービスペース寸法とする。
- 3) 取付ネジは +トラスタツピンネジ呼び径 4 x 1.6 を使用のこと。

NOTE

1. TABLE 1 INDICATES TOLERANCE OF DIMENSIONS WHICH IS NOT SPECIFIED.
2. # MINIMUM SERVICE CLEARANCE.
3. USE TAPPING SCREWS $\phi 4 \times 1.6$ FOR FIXING THE UNIT.

DRAWN	22/Mar/2011 I. YAMASAKI	TITLE	CI-6888
CHECKED	22/Mar/2011 H. MAKI	名称	操作部 (卓上装備)
APPROVED	22/Mar/2011 Y. NISHIYAMA	外寸図	
SCALE	1/3 MASS 1.9 kg	NAME	CONTROL UNIT (TABLETOP MOUNT)
DWG. No.	C7252-G02-B	REF. No.	66-030-310G-2



表 1
TABLE 1

寸法区分 (mm) DIMENSIONS	公差 (mm) TOLERANCE
L ≤ 50	± 1.5
50 < L ≤ 100	± 2.5
100 < L ≤ 500	± 3

取付穴寸法図 尺度 1/10
CUTOUT DIMENSIONS (SCALE: 1/10)

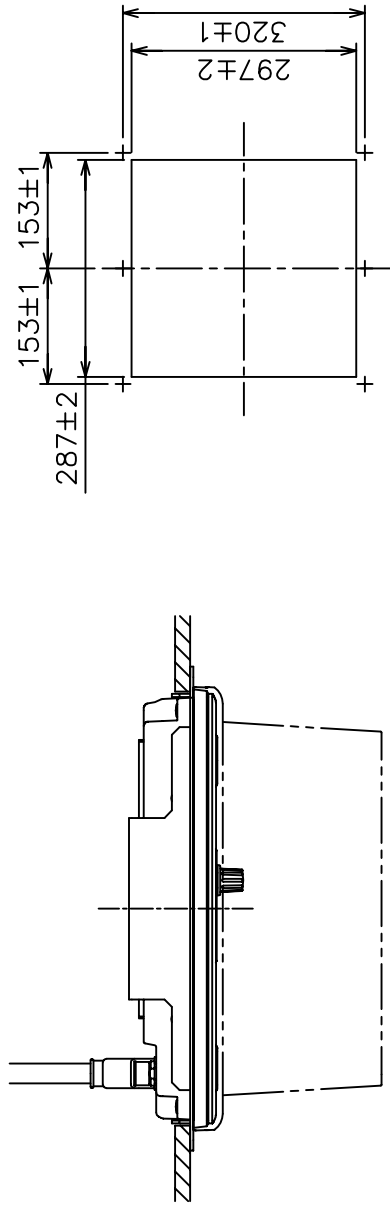
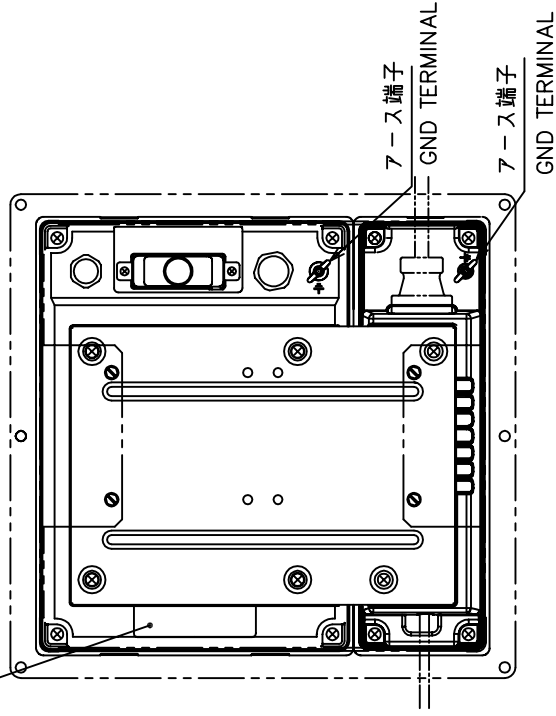
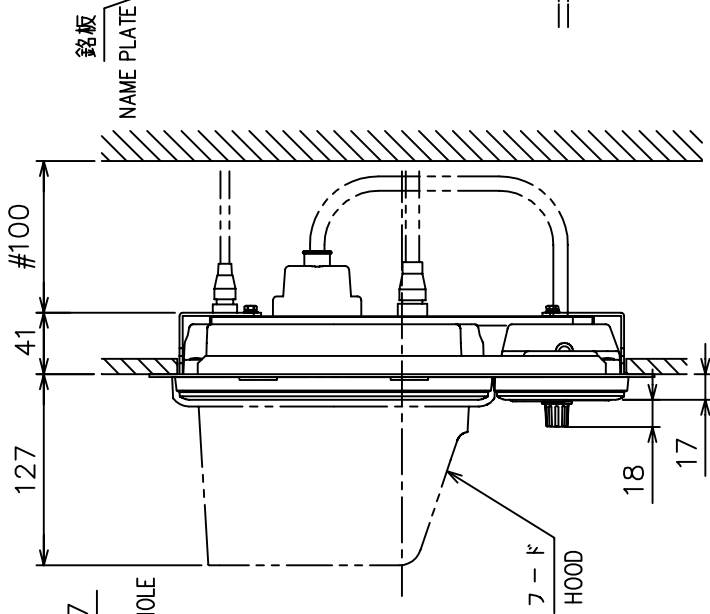
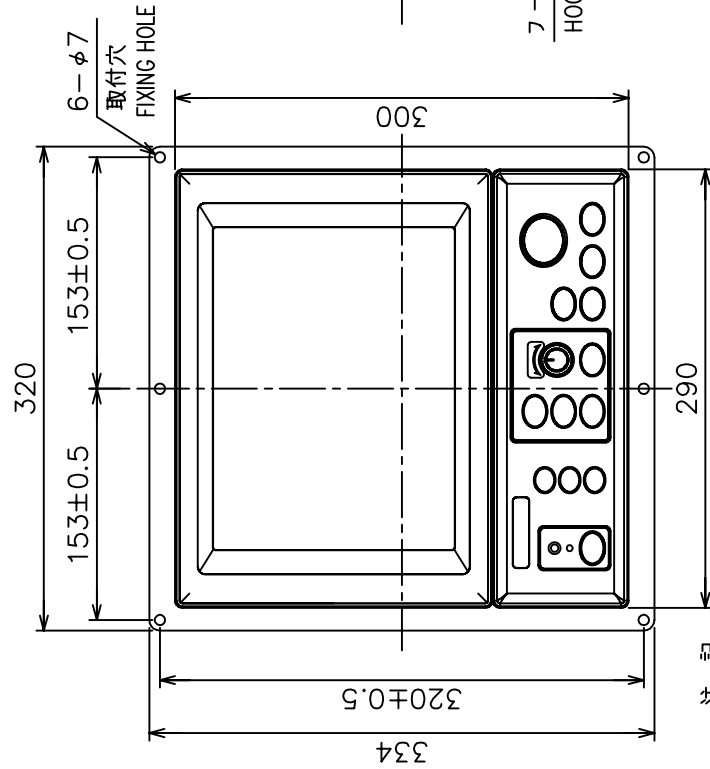

注記

- 1) 印寸法は最小サービス空間寸法とする。
 - 2) 指定外の寸法公差は表1による。
 - 3) 取付用ネジは+トラスタップピニングネジ呼び径5×2.0を使用のこと
 - 4) 装備ケーブルはサービス時、本体を前方に十分引き出せるよう余裕を持たせること。
- NOTE
1. # MINIMUM SERVICE CLEARANCE.
 2. TABLE 1 INDICATES TOLERANCE OF DIMENSIONS WHICH IS NOT SPECIFIED.
 3. USE TAPPING SCREWS 5x2.0 FOR FIXING UNIT.
 4. KEEP ENOUGH CABLE LENGTH BEHIND UNIT.

DRAWN Oct. 22 '03 CHECKED Takahashi T.	TITLE MU-100C+O-6888 名称 表示部 + 操作部 (埋込装備)
APPROVED Y. Hatai SCALE 1/5	DATE 01-68/88 外寸図
DRWG. No. C7252-G04-B	NAME MONITOR UNIT AND CONTROL UNIT (FLUSH MOUNT) OUTLINE DRAWING
	66-030-320G-1

4

3

2

表 1 TABLE 1

寸法区分 (mm) DIMENSION	公差 (mm) TOLERANCE
0 < L ≤ 50	±1.5
50 < L ≤ 100	±2.5
100 < L ≤ 500	±3

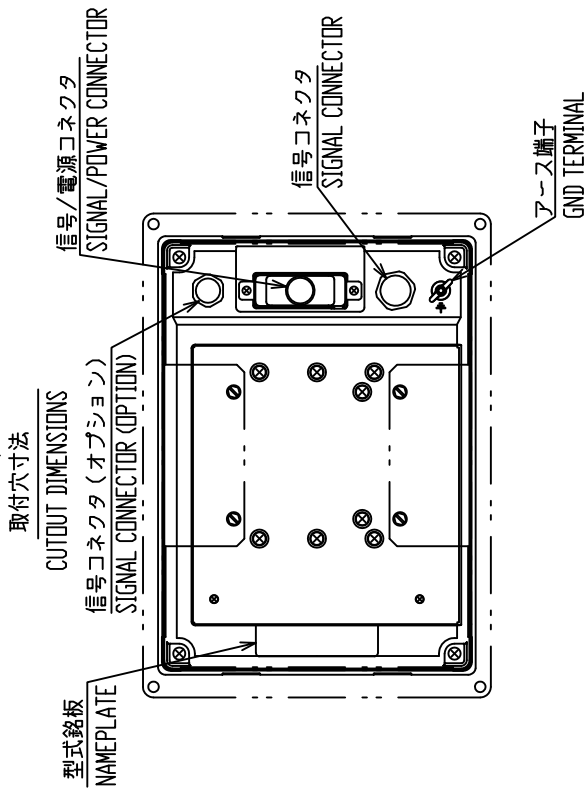
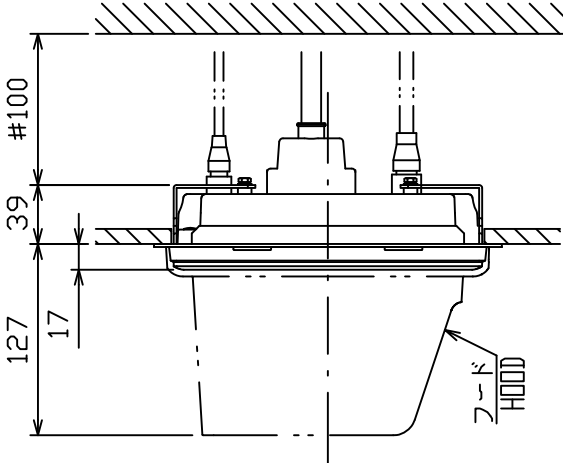
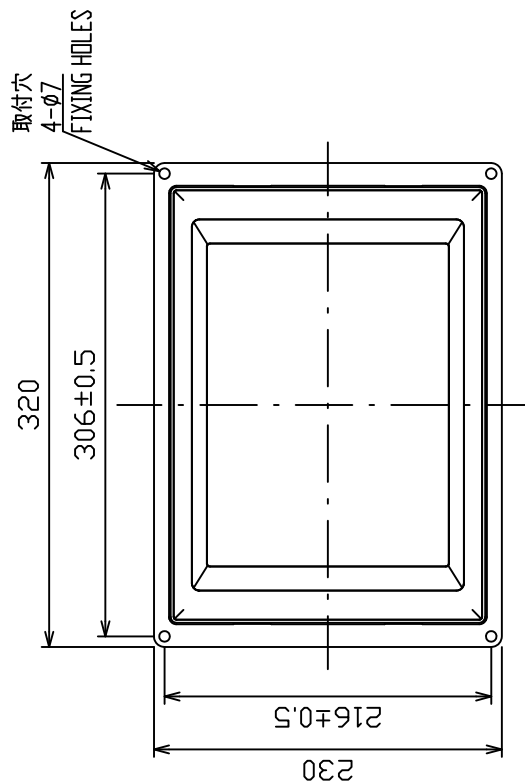
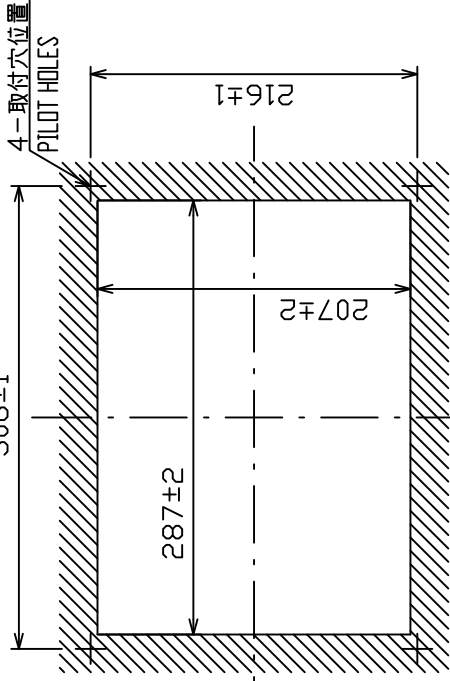

- 注記 1) 指定外の寸法公差は表 1 による。
 2) 印寸法は最小サービス空間寸法とする。
 3) 取付用ネジは+トラスタッピングネジ呼び径5×20を使用のこと。
 4) 装備ケーブルは、サービス時、本体を前方に十分引き出せるよう余裕を持たせること。
- NOTE 1. TABLE 1 INDICATES TOLERANCE OF DIMENSIONS WHICH IS NOT SPECIFIED.
 2. # MINIMUM SERVICE CLEARANCE.
 3. USE TAPPING SCREWS Ø5×20 FOR FIXING THE UNIT.
 4. KEEP SUFFICIENT CABLE LENGTH SO THAT THE UNIT CAN BE DRAWN FORWARD WITHOUT DISCONNECTING CABLING.

DRAWN	18/Mar/2015	I. YAMASAKI	TITLE	MU-100C
CHECKED	18/Mar/2015	H. MAKI	名称	表示部 (分離型、埋込装備)
APPROVED	19/Mar/2015	H. MAKI	外寸図	
SCALE	1/5	MASS 2.7 kg	NAME	MONITOR UNIT (SEPARATE, FLUSH MOUNT)
DWG. No.	C1316-G10-C		DWG. No.	06-021-193G-1
				OUTLINE DRAWING

表 1
TABLE 1

寸法区分 (mm) DIMENSIONS	公差 (mm) TOLERANCE
$L \leq 50$	± 1.5
$50 < L \leq 100$	± 2.5
$100 < L \leq 500$	± 3

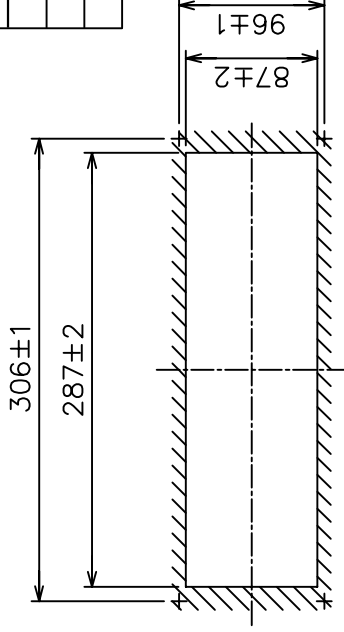

取付穴寸法図
CUTOUT DIMENSIONS

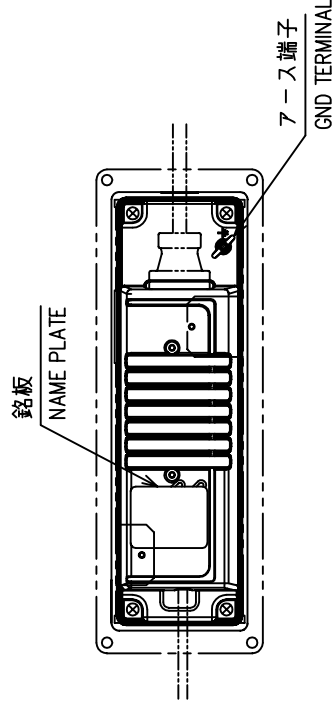
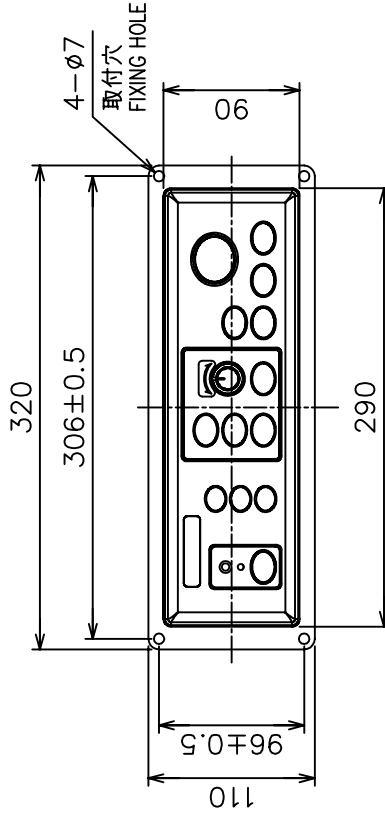
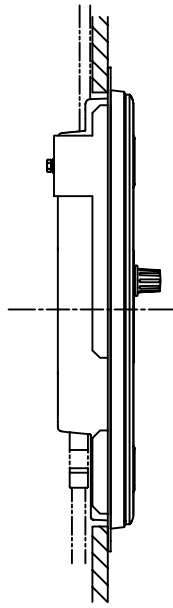
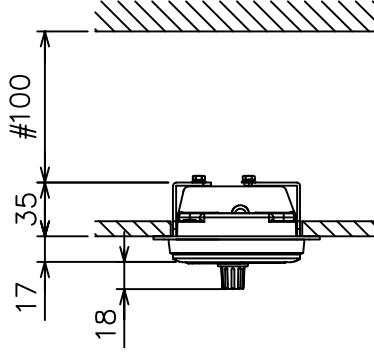

注 記

- 1) #印寸法は最小サービス空間寸法とする。
- 2) 指定外の寸法公差は表1による。
- 3) 取付用ネジは+トラスタップピンクネジ呼び径5×2.0を使用のこと
- 4) 装備ケーブルはサービス時、本体を前方に十分引き出せるよう余裕を持たせること。

NOTE

1. # MINIMUM SERVICE CLEARANCE.
2. TABLE 1 INDICATES TOLERANCE OF DIMENSIONS WHICH IS NOT SPECIFIED.
3. USE TAPPING SCREWS 5x2.0 FOR FIXING UNIT.
4. KEEP ENOUGH CABLE LENGTH BEHIND UNIT.

DRAWING	Oct. 22 '03 E. MIYOSHI	TITLE	CI-6888
CHECKED	Takahashi T.	名称	操作部 (埋込装備)
APPROVED	Y. Hatai	外寸図	
SCALE	1/5 MASS 1.9 ±10% lg	NAME	CONTROL UNIT (FLUSH MOUNT)
DWG No.	C7252-G05-A		OUTLINE DRAWING
	66-030-330G-0		



表 1 TABLE 1

寸法区分 (mm) DIMENSION	公差 (mm) TOLERANCE
$0 < L \leq 50$	± 1.5
$50 < L \leq 100$	± 2.5
$100 < L \leq 500$	± 3

注記 指定なき寸法公差は表 1 による。

NOTE TABLE 1 INDICATES TOLERANCE OF DIMENSIONS.

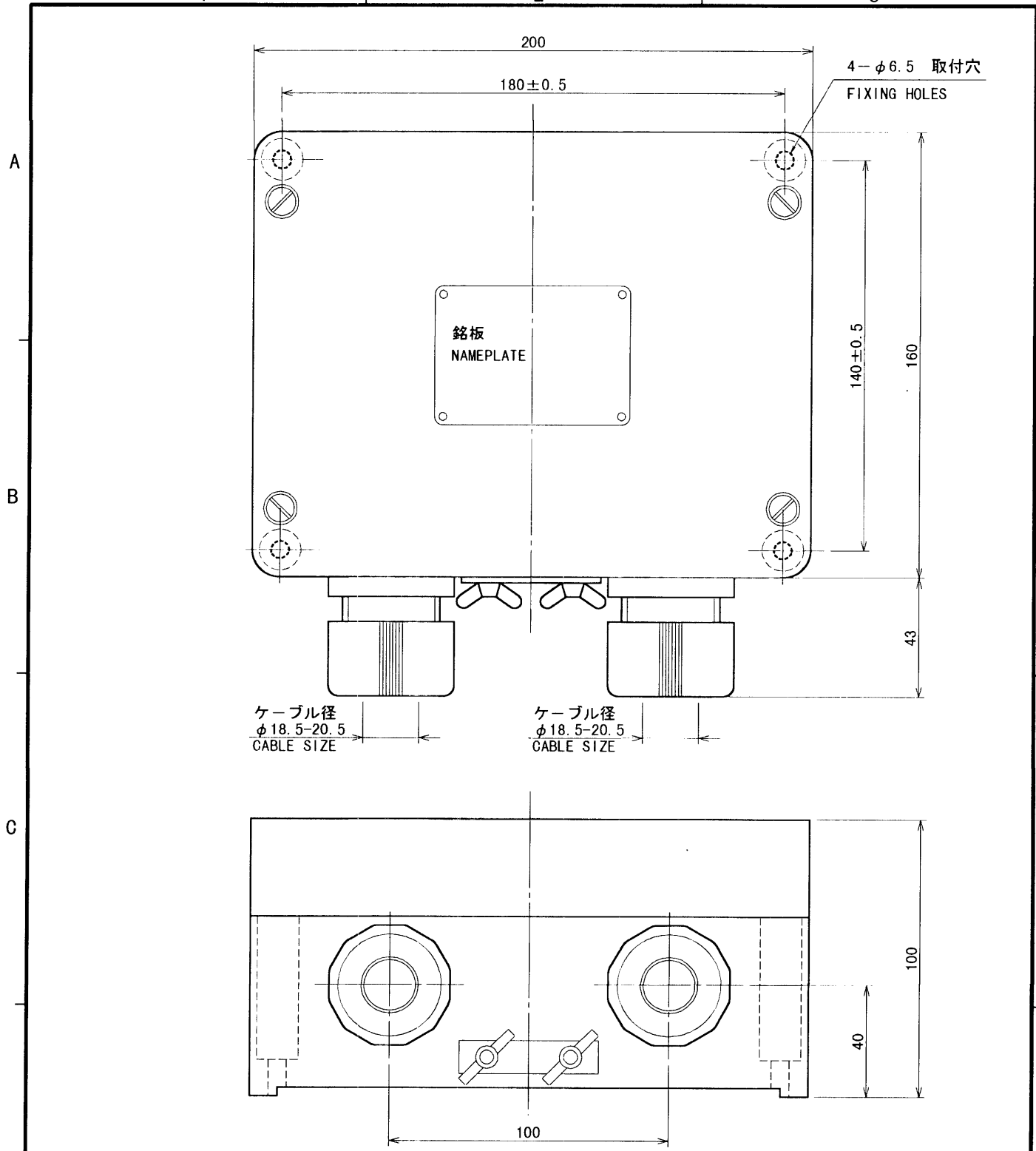
DRAWN Apr. 17 '00 T. YAMASAKI		TITLE CI-630	
CHECKED Apr. 17 '00 Y. Kim		名称 接続箱	
APPROVED Apr. 17 '00 Y. Kim		外寸図	
SCALE 1/2	MASS 2 $\pm 10\%$ kg	NAME JUNCTION BOX	
DWG. No. C7228-G03- D		OUTLINE DRAWING	

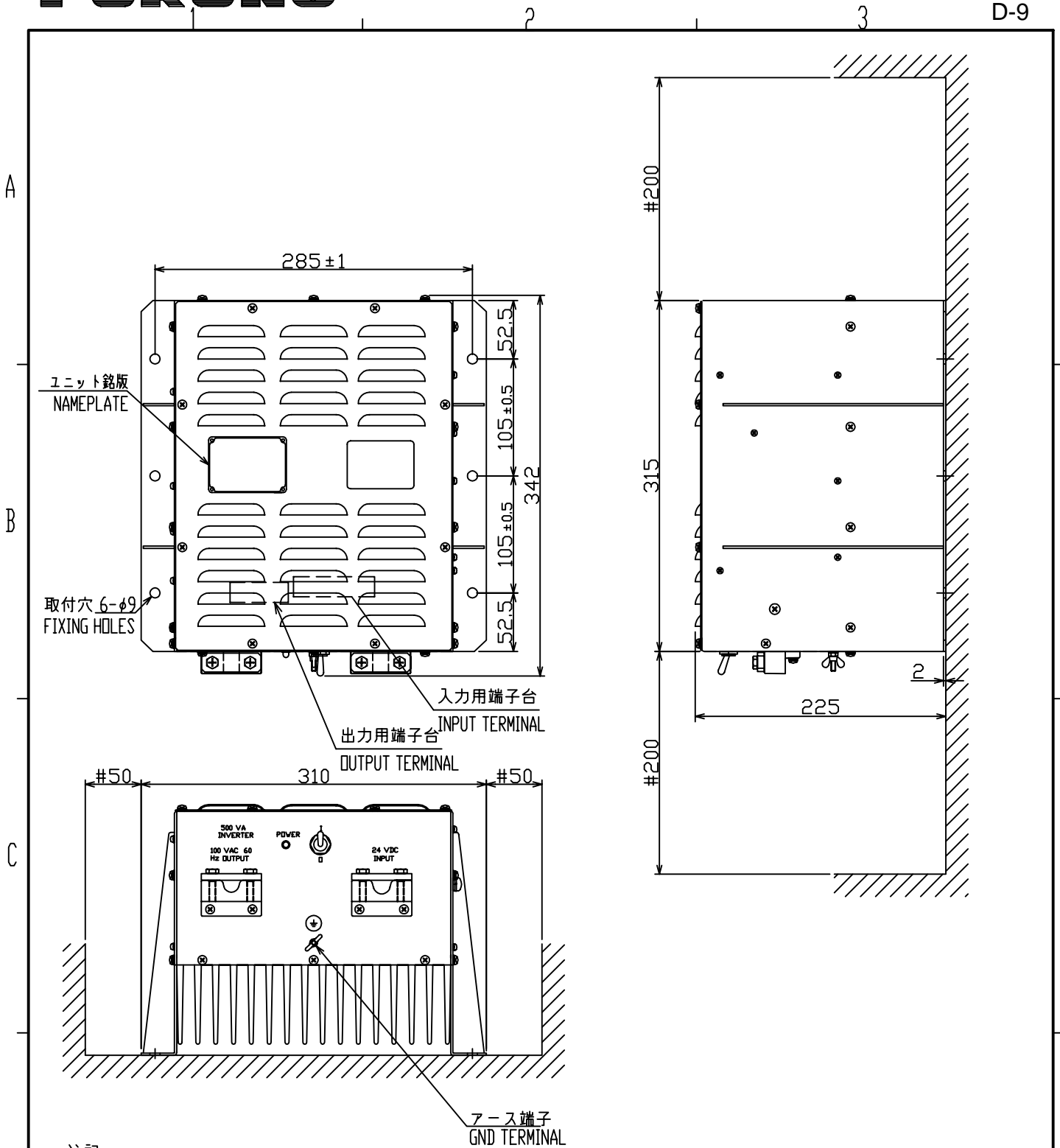

注記

- 1) 指定なき寸法公差は表1による。
- 2) #：推奨するサービス空間寸法。
- 3) 取付けにはM8ボルトまたはコーチボルト呼び径8を使用のこと。

NOTE

- 1. TABLE 1 INDICATES TOLERANCE OF DIMENSIONS.
- 2. #: RECOMMENDED SERVICE CLEARANCE.
- 3. USE M8 BOLTS OR COARCH SCREWS φ8 FOR FIXING THE UNIT.

寸法区分(mm) DIMENSION	公差(mm) TOLERANCE
0 < L ≤ 50	±1.5
50 < L ≤ 100	±2.5
100 < L ≤ 500	±3

表1 TABLE 1

DRAWN	Dec. 13 '02 T.YAMASAKI		TITLE	TR-2451
CHECKED	Dec. 16 '02 Y.KIMURA		名称	DC/ACインバータ
APPROVED		CSH-5L/8L		外寸図
SCALE	1/5	MASS 15 ±10% kg	NAME	DC/AC INVERTER
DWG.No.	C1319-G04-B			OUTLINE DRAWING

寸法区分 (mm) DIMENSION	公差 (mm) TOLERANCE
0 < L ≤ 50	±1.5
50 < L ≤ 100	±2.5
100 < L ≤ 500	±3

表 1
TABLE 1

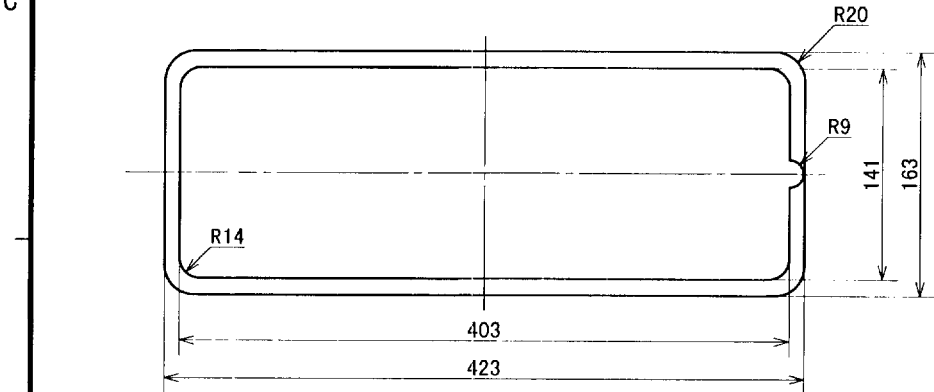
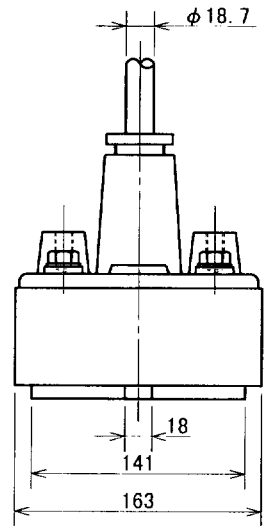
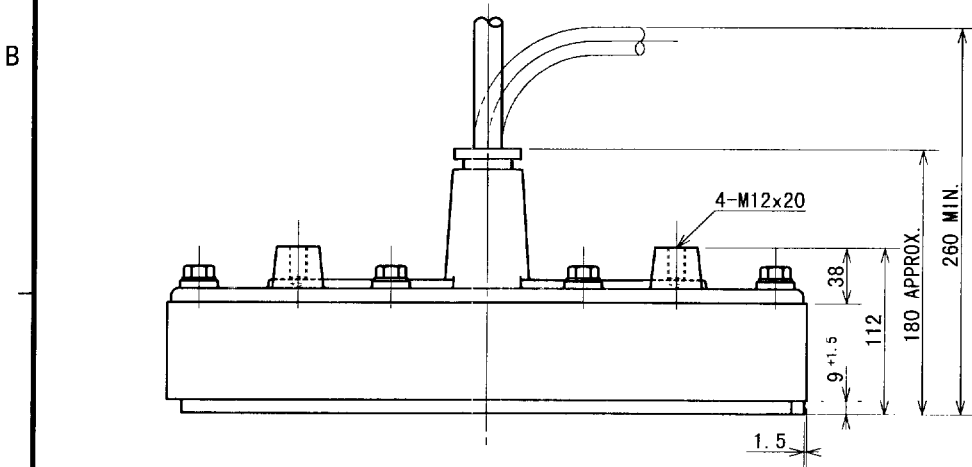
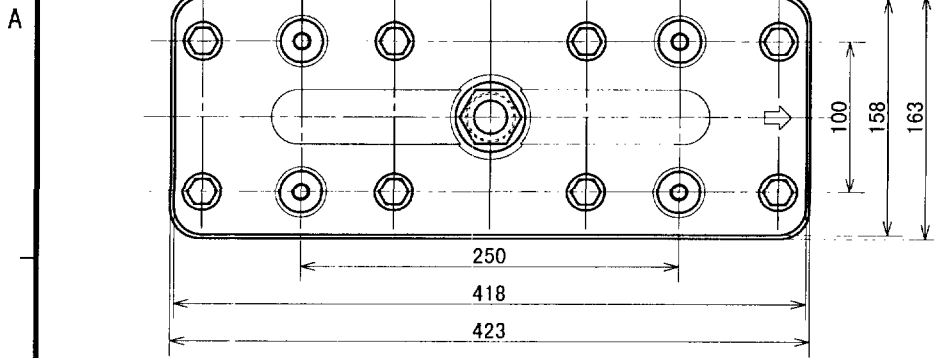

注記 1) 指定なき寸法公差は表 1 による。
 NOTE 1. TABLE 1 INDICATES TOLERANCE OF DIMENSIONS.

CI-620-1 : 21 kg (10mケーブル付 W/ 10m CABLE)
 CI-620-2 : 26 kg (20mケーブル付 W/ 20m CABLE)

DRAWN <i>Oct 1 '99 T. YAMASAKI</i>		TITLE CI-620
CHECKED <i>Oct 1 '99 K. Kusumoki</i>		名称 送受波器
APPROVED <i>Oct 1 '99 K. Kusumoki</i>		外寸図
SCALE 1/5	MASS kg	NAME TRANSDUCER
DWG. No. C7228-G04- E		OUTLINE DRAWING

18	GASKET	RUBBER	1	TPB-1003
17	WASHER	SS41	1	TPB-1002-1

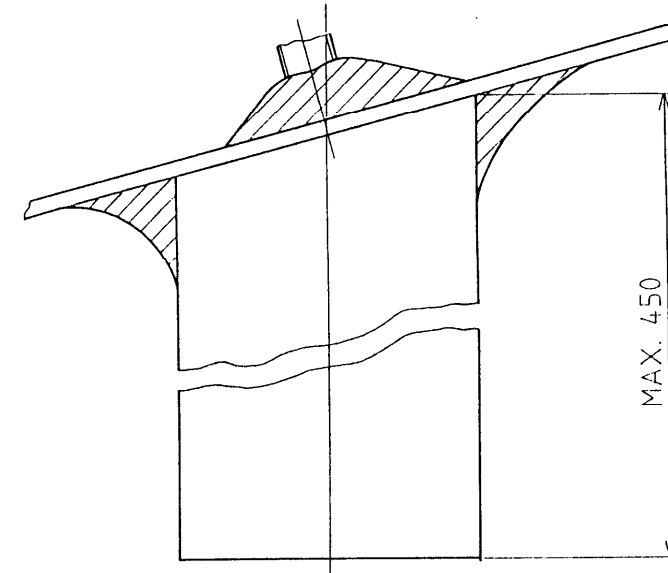
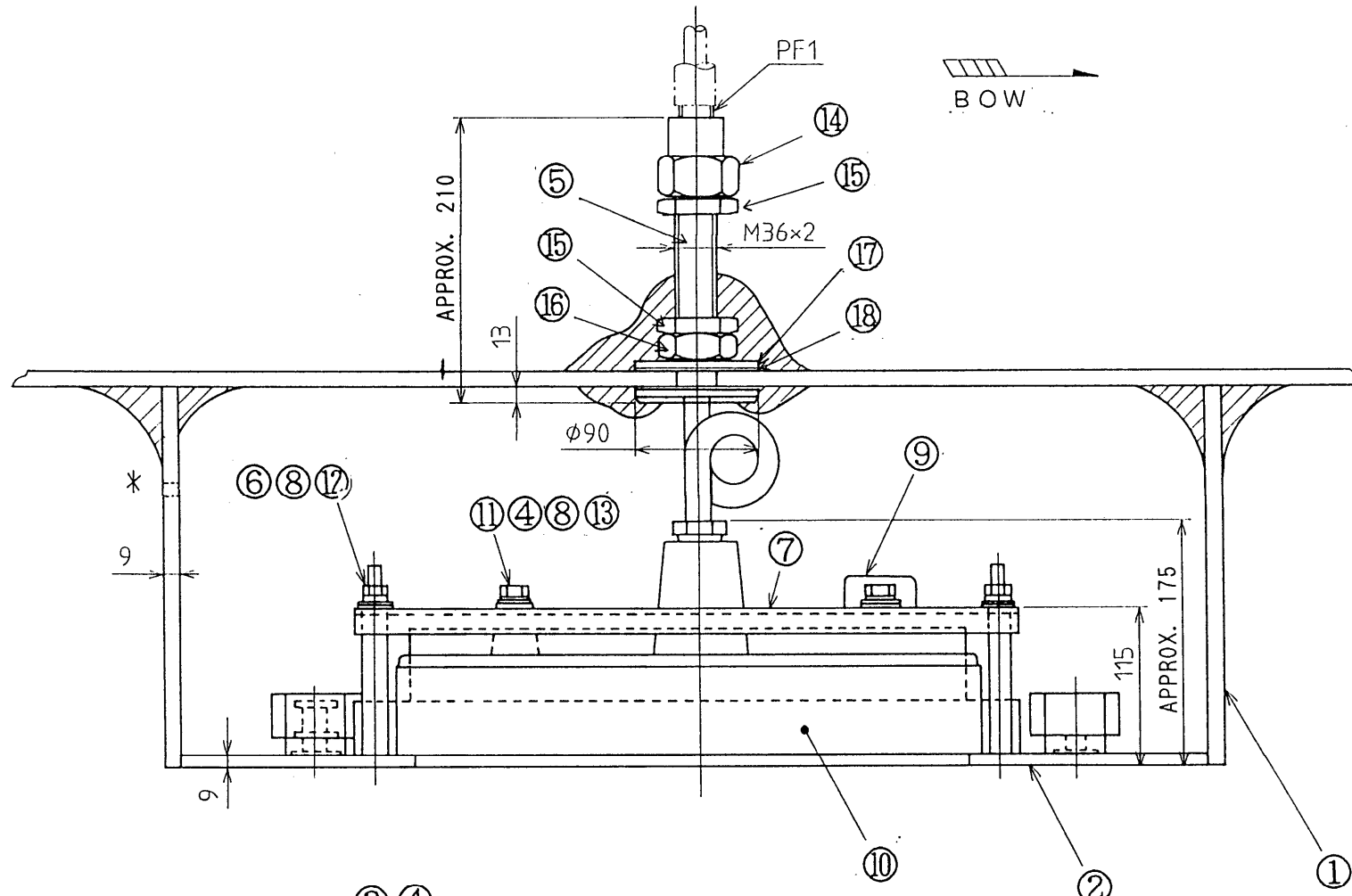

PRINCIPAL ITEM		
POSITION	FROM BOW	m
	FROM KEEL	mm
PROJECTION		mm
FIXING CONDITION		HORIZONTAL AT RUNNING
PROTECTION TANK		

品番 ITEM	品名 NAME	材質 MATERIAL	数量 Q'TY	図番 DWG.NO.	摘要 REMARKS
16	FIXING NUT	SS400	1	TPB-1-03	
15	LOCK NUT	SS400	2	TPB-1-04	
14	CAP NUT	SS400	1	66-017-1506-1	
13	FLAT WASHER	PC	4		
12	FLAT WASHER	RESIN	4		
11	HEX. BOLT	SUS304	4		M12x25
10	TRANSDUCER		1		STD: WITH 10m CABLE
9	ZINC BLOCK		1		
8	FLAT WASHER	SUS304	8		
7	FIXING PLATE	SS400	1		
6	HEX. NUT	SUS304	8		M12
5	THRU-HULL PIPE	BC2	1	66-017-1501-0	
4	SPRING WASHER	BC2	8		M12
3	HEX. BOLT	SUS304	4		M12x4.0
2	FIXING FLANGE	SS400	1		
1	CASING	FRP	1		

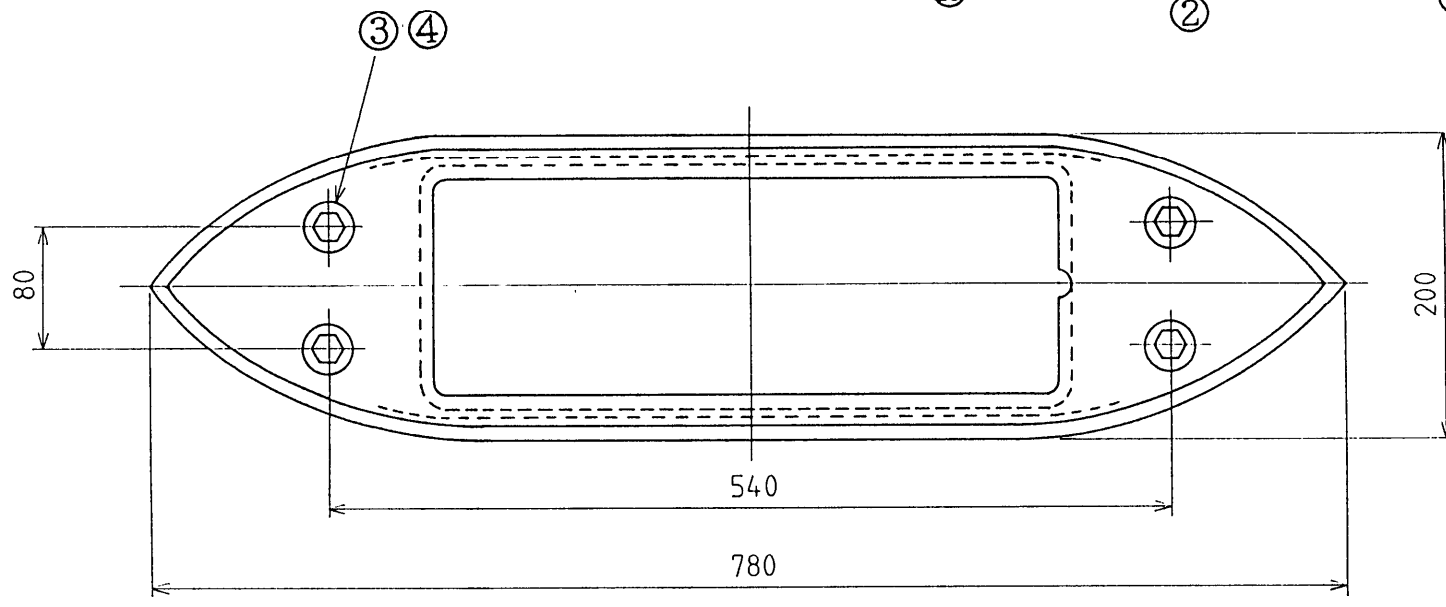

- NOTE**
- DECIDE PRINCIPAL ITEMS UPON DISCUSSING WITH SHIP'S OWNER OR SHIPYARD.
 - CUT CASING FOR θ (RING ANGLE OF SHIP'S HULL).
 - ALLOW ENOUGH CLEARANCE AROUND THRU-HULL PIPE FOR EASY TIGHTENING AND SERVICING.
 - FRP MOLD THRU-HULL PIPE ON BOTH SIDES OF HULL PLATE.
 - DO NOT PAINT TRANSDUCER FACE.
 - FRP MOLD INSIDE OF CASING.
 - BEFORE FIXING CASING TO HULL PLATE, FIRST CLEAN HULL PLATE SURFACE WITH A SANDER UNTIL FIBER GLASS APPEARS ON FACE, THEN REMOVE DUSTS, OILS AND SO ON FROM SURFACE.
 - * MAKE A HOLE OF 10 TO 20MM DIA. ON STERN SIDE TO ALLOW WATER TO PENETRATE.

承認 APPROVED	APR. 24 '90 T. NAKAWO	三角法 THIRD ANGLE PROJECTION		名称 TITLE	CI-620-T-F TRANSDUCER INSTALLATION (FOR FRP)
検図 CHECKED	APR. 23 '90 M. IKEDA	尺度 SCALE	1/5	重量 WEIGHT	4.6 kg
製図 DRAWN	APR. 23 '90 TAKAHASHI	重量 WEIGHT		図番 DWG.NO.	E7228-T01-B

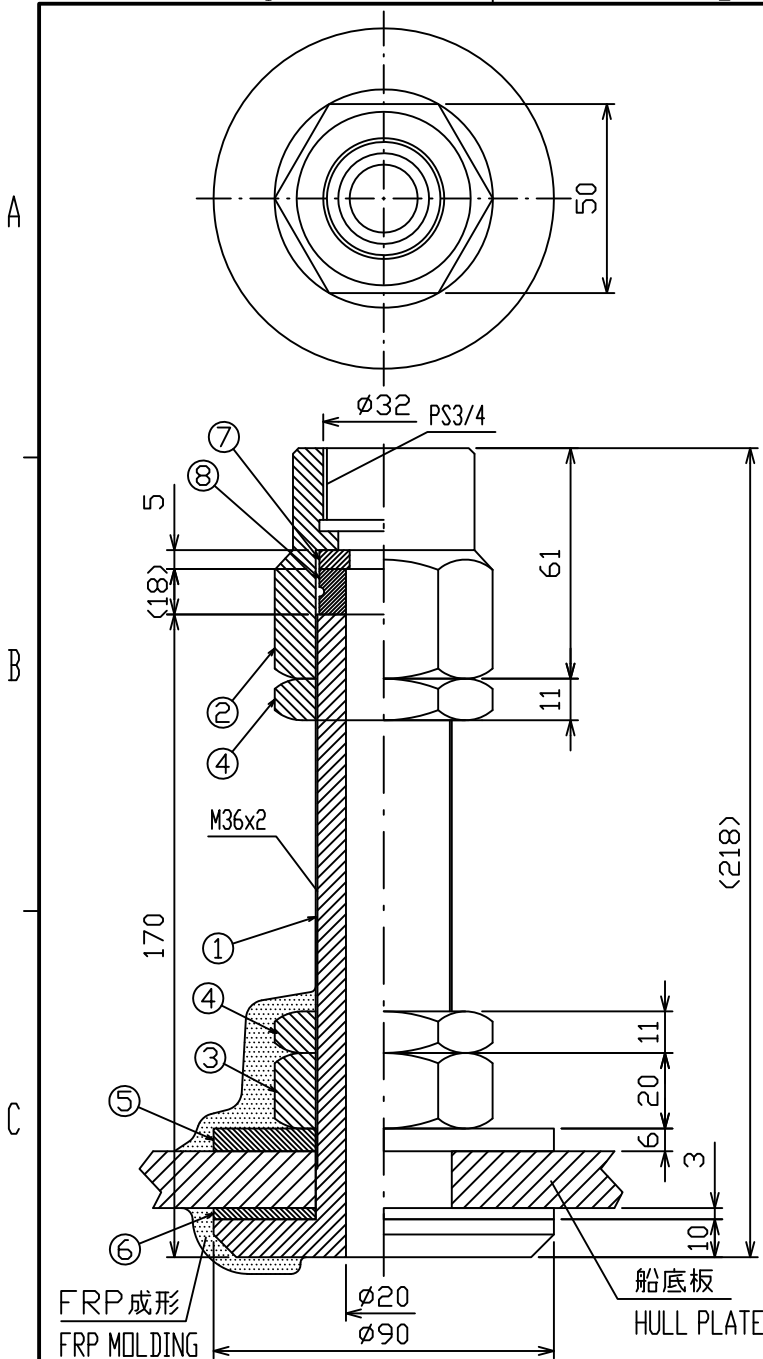

キャップナットの締付手順

1. 貫通金物用体①のネジ部に、シールテープを巻く。
2. キャップナット②を手で回せるだけ一杯ねじ込む。
3. さらにスパナで2回転程度締め付ける。ただし、強く締めすぎるとパッキン⑧が圧縮されて芯線を切断することがあるので、漏水を防ぐ程度以上には締めないこと。
4. 最後に止めナット④で固定する。

PROCEDURE TO TIGHTEN CAP NAT

1. APPLY SEAL TAPE TO THREAD OF PIPE① FOR WATERTIGHTNESS.
2. SCREW CAP NUT② ONTO PIPE BY HAND.
3. THEN CONTINUE ABOUT TWO TURNS WITH A SPANNER. NEVER TIGHTEN CAP NUT② TOO MUCH. EXCESSIVE TIGHTENING MAY CAUSE DAMAGES ON THE CABLE.
4. TIGHTEN LOCK NUT④.

8	パッキン GASKET	CR	1	VA25	
7	平座金 FLAT WASHER	SUS304	1	66-017-1402	
6	船底用パッキン GASKET	NR	1	TRB-1003	FIBERED
5	船底用座金 WASHER	SS41	1	TRB-1002	
4	止めナット LOCK NUT	SS41	2	TPB-1-04	
3	船底締付ナット FIXING NUT	SS41	1	TPB-1-03	
2	キャップナット CAP NAT	SS41	1	66-017-1506	
1	貫通金物用体 THRU-HULL PIPE	BC2	1	66-017-1501	
品番 ITEM	品名 NAME	材質 MATERIAL	数量 Q'TY	図番 DWG.NO.	摘要 REMARKS

DRAWN	28/Mar/2013 T.YAMASAKI	TITLE	CI-620-K-F
CHECKED	28/Mar/2013 H.MAKI	名称	電線貫通金物 (FRP 船用)
APPROVED	29/Mar/2013 Y.NISHIYAMA	CI-60/60G	外寸図
SCALE	1/2 MASS 25 ±10% kg	NAME	THRU-HULL PIPE FOR FRP
DWG. No.	C7228-G07-C	REF. No.	OUTLINE DRAWING



表1 (Table1)

寸法区分 (mm) Dimension	公差 (mm) Tolerance
L ≤ 50	±1.5
50 < L ≤ 100	±2.5
100 < L ≤ 500	±3
500 < L ≤ 1000	±4

要目表 PRINCIPAL ITEMS		
位置 POSITION	船首から FROM BOW	m
	キールから FROM KEEL	mm
突出量 H PROJECTION		mm
取付状態 FIXING CONDITION	走行時水平 HORIZONTAL AT RUNNING	
保護タンク PROTECTION TANK		

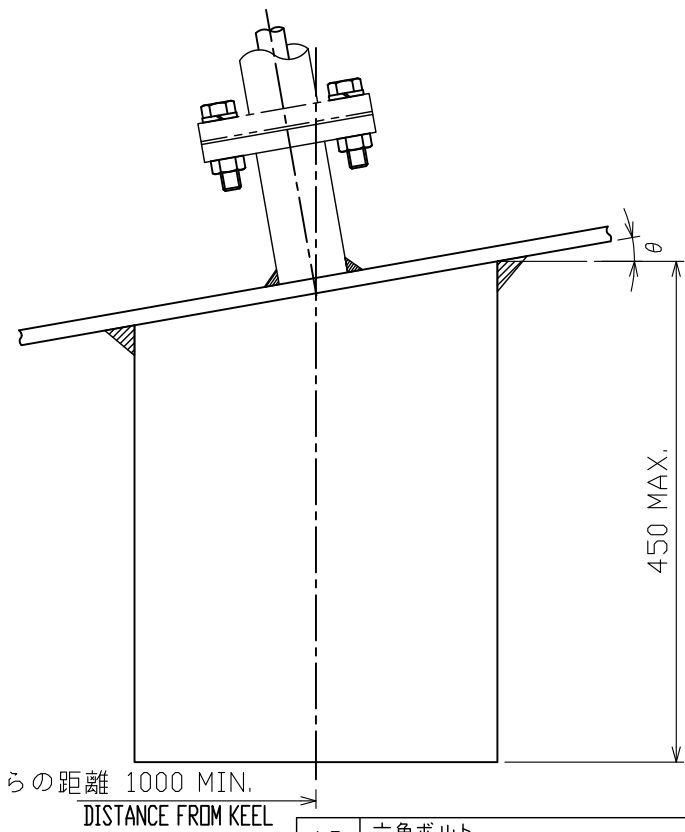
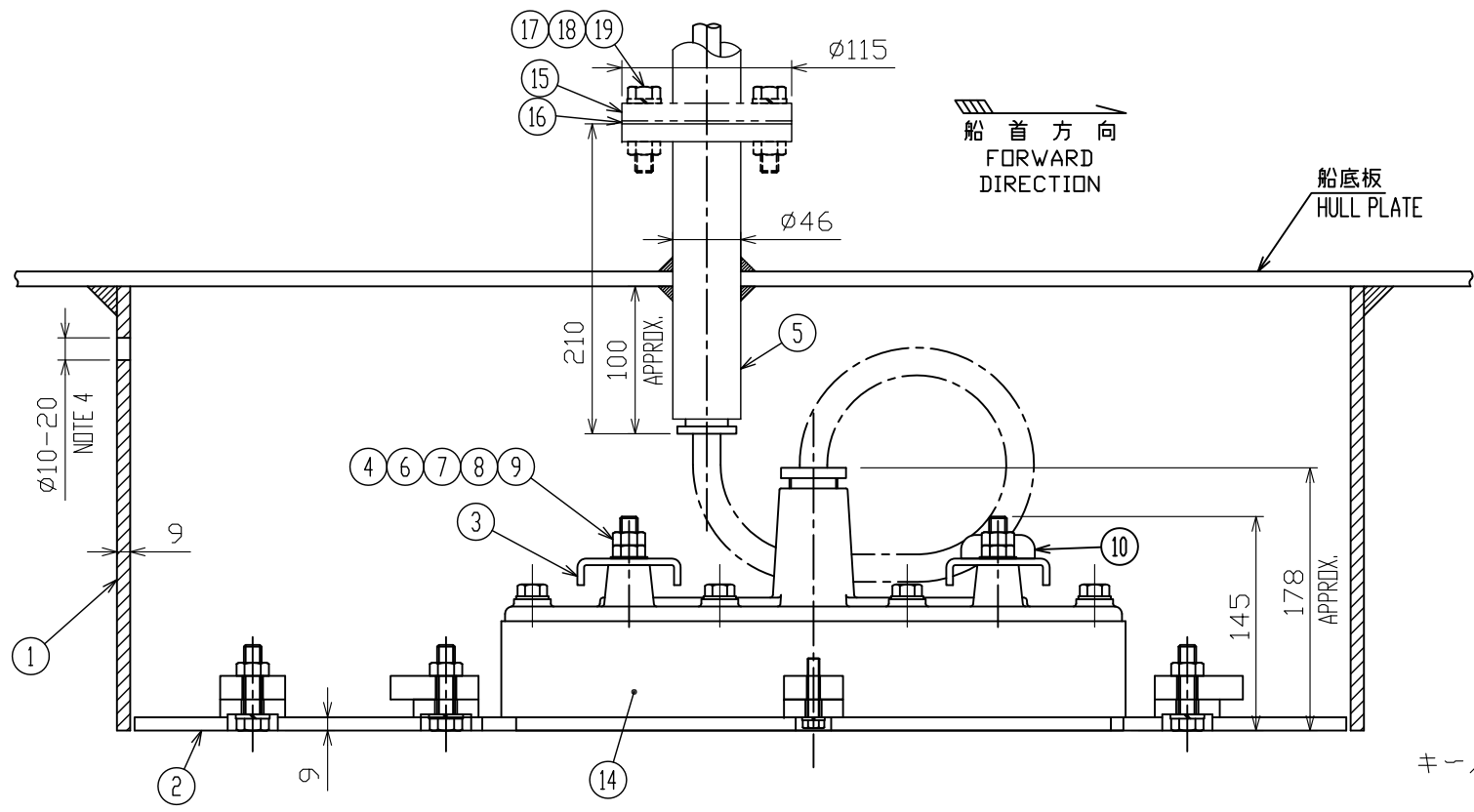
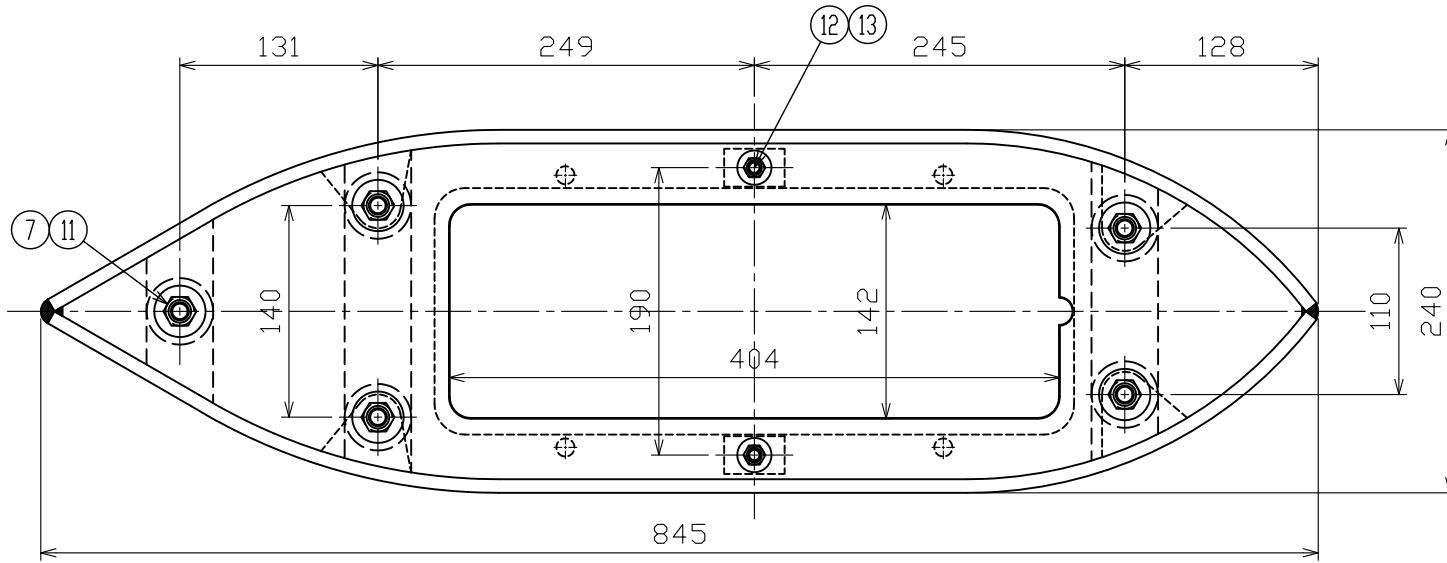

品番 ITEM	品名 NAME	材質 MATERIAL	数量 QTY	図番 DWG. NO.	摘要 REMARKS
19	六角ボルト HEX. BOLT	SUS304	4	M12	造船所手配 SHIPYARD SUPPLY
18	バネ座金 SPRING WASHER	SUS304	4	M12	
17	六角ボルト HEX. BOLT	SUS304	4	M12×40-50	
16	パッキン GASKET	CR	1		
15	呼び圧力5k差込溶接式フランジ STEEL WELDING PIPE FLANGE (5KPa)	SS41	1	JISB2220-5K-10	質量に含まず NOT INCLUDED IN MASS
14	送波器 TRANSDUCER		1	CI-620	
13	六角ボルト HEX. BOLT	SUS304	5	M8×40	
12	バネ座金 SPRING WASHER	SUS304	2	M8	
11	六角ボルト HEX. BOLT	SUS304	2	M12×40	
10	防蝕亜鉛 ZINC PLATE	ZAP	1	B-1 1/2	造船所手配 SHIPYARD SUPPLY
9	平座金 FLAT WASHER	POM	4	T-201-11	
8	平座金 FLAT WASHER	SUS304	4	M12	
7	バネ座金 SPRING WASHER	SUS304	9	M12	
6	六角ナット HEX. NUT	SUS304	8	M12	
5	電線貫通金物 THRU-HULL PIPE	SS400	1	CI-620-K-S	
4	スペーサ SPACER	SGP	4	66-017-1204	
3	押え板 FIXING PLATE	SGP	2	66-017-1203	
2	送波器取付フランジ FIXING FLANGE	SGP	1	66-017-1202	
1	送波器ケース CASING	SS41	1	66-017-1201	

- 注記
- 指定外の寸法公差は、表1の通りです。
 - 送波器ケースは船底傾斜角(θ)にあわせて切断してください。
 - 切断・溶接の際は、歪み防止のため送波器を取り外した状態で“フランジ”を必ず取り付けておいてください。溶接方法は造船所一任。
 - 船尾側上端に空気抜き用穴(φ10~φ20程度)をあけてください。
 - 電線貫通金物はフレーム等の邪魔にならない所で送波器に当たらず、キャップナットが容易に締め付けられる位置に取り付けてください。
 - 網除け、保護タンクは必要に応じて造船所にて製作してください。
 - 送波器面を塗装しないように注意してください。
 - 送波器ケース取付の際には船首、船尾の確認をしてください。
 - 送波器面が吃水に平行になるように装備してください。
- NOTE
- TABLE 1 INDICATES TOLERANCE OF DIMENSIONS WHICH IS NOT SPECIFIED.
 - CUT CASING FOR RISING ANGLE (θ) OF SHIP'S HULL.
 - TO AVOID DISTORTION BY HEAT, PUT "FIXING FLANGE" ONTO CASING (WITHOUT TRANSDUCER) WHILE CUTTING AND/OR WELDING.
 - MAKE A HOLE φ10-20 TO ESCAPE AIR ON THE UPPER SIDE OF AFT-TANK.
 - ALLOW SUFFICIENT CLEARANCE AROUND THRU-HULL PIPE FOR EASY TIGHTENING AND SERVICING.
 - NET-PROTECTOR OR PROTECTIVE TANK SHOULD BE PREPARED BY SHIPYARD.
 - DO NOT PAINT TRANSDUCER FACE.
 - MAKE SURE THE FORE DIRECTION OF THE CASING.
 - THE FACE OF TRANSDUCER SHOULD BE PARALLEL WITH THE WATERLINE ON SAILING.

DRAWN	11/May/2013 T.YAMASAKI	TITLE	CI-620-T-S	
CHECKED	13/May/2013 H.MAKI	名称	送波器タンク(鋼船用)	
APPROVED	14/May/2013 H.MAKI		送波器装備図	
SCALE	1/5 MASS 94 ±10% kg	質量は送波器を含みません。 MASS DOES NOT INCLUDE TRANSDUCER.	NAME	TRANSDUCER TANK (STEEL HULL)
DWG No.	C7228-T02-G	REF. No.		TRANSDUCER INSTALLATION

表 1

寸法区分 (mm)	公差 (mm)
$0 < L \leq 50$	± 1.5
$50 < L \leq 100$	± 2.5
$100 < L \leq 500$	± 3

A

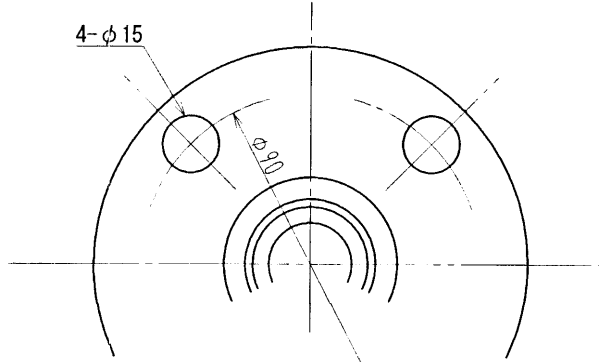

B

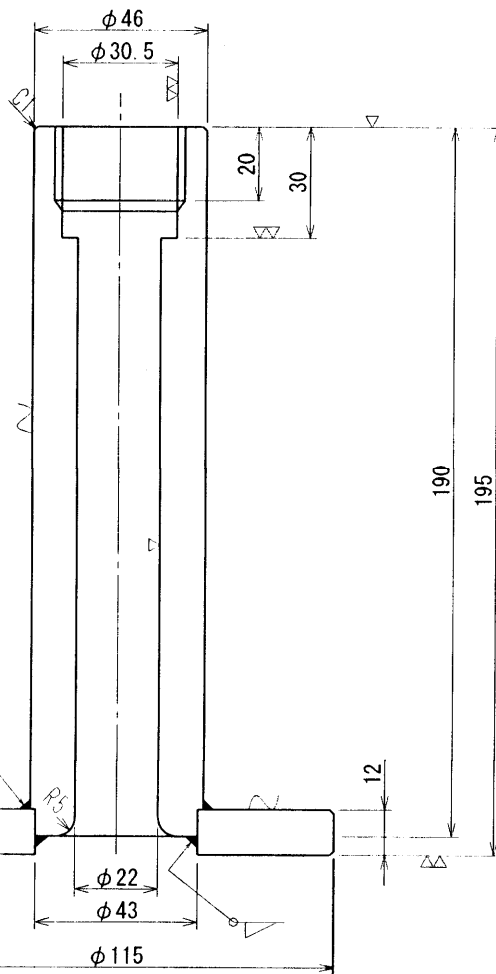

C

注2)
呼び圧力 5 k
差込溶接式フランジ
JIS B2220
呼び径 32 使用可

D

注記

1) 指定なき寸法公差は表 1 による。

DRAWN July 26 '00 T. YAMASAKI		TITLE CI-620-K-S
CHECKED July 27 '00 Y. K.		名称 船底貫通金物
APPROVED July 27 '00 Y. K.		外寸図
SCALE 1/2	MASS $\pm 10\%$ kg	NAME THRU-HULL PIPE
DWG. No. J7228-G08-B	66-017-1401-0	OUTLINE DRAWING

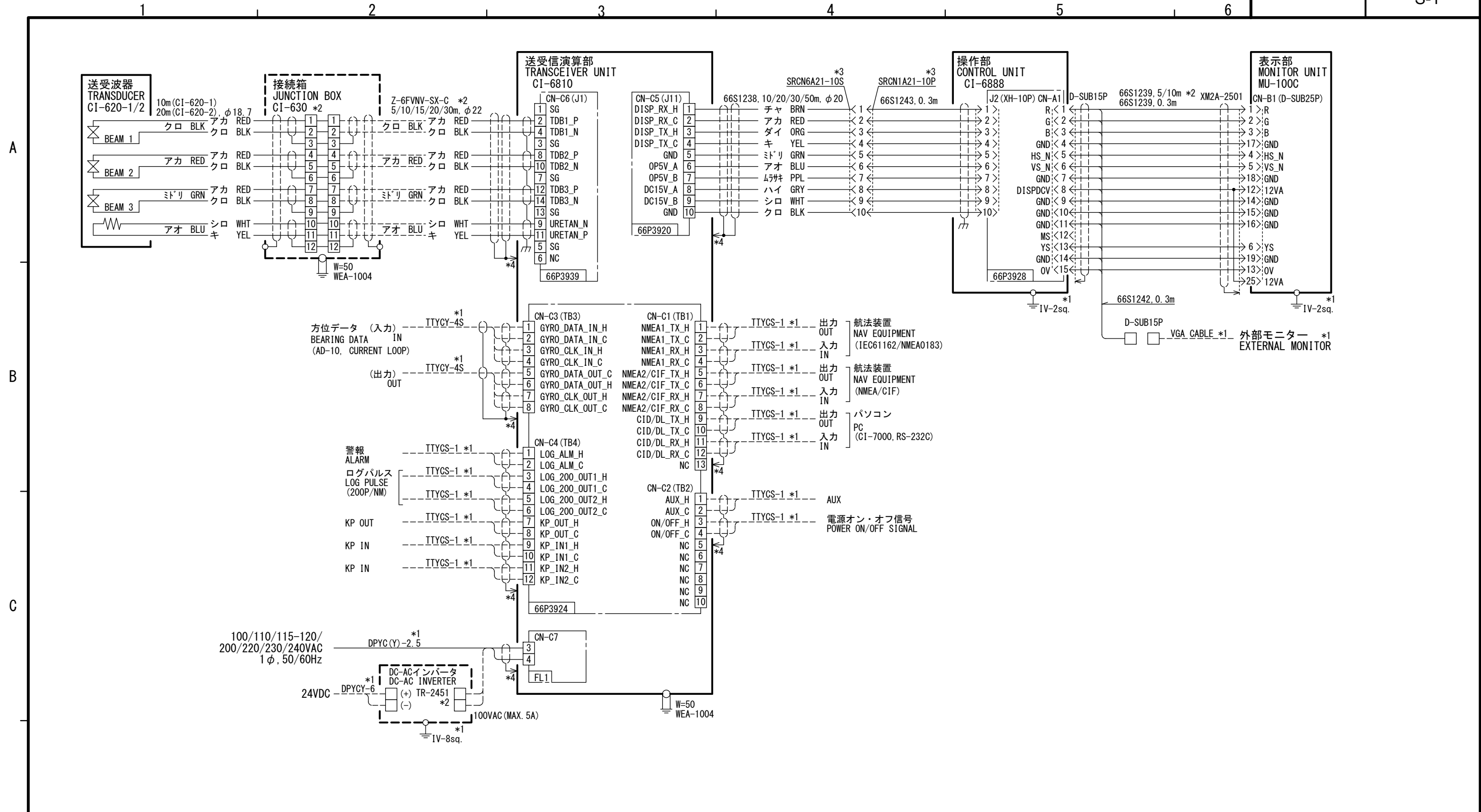

A

B

C

D

注記
 * 1) 造船所手配。
 * 2) オプション。
 * 3) コネクタは工場にて取付済み。
 * 4) ケーブルクランプにてアースする。

NOTE
 *1: SHIPYARD SUPPLY.
 *2: OPTION.
 *3: CONNECTOR PLUG FITTED AT FACTORY.
 *4: GROUND THRU CABLE CLAMP.

DRAWN 5/Aug/2015 T. YAMASAKI	TITLE CI-68
CHECKED 5/Aug/2015 H. MAKI	名称 カラー潮流計
APPROVED 7/Aug/2015 H. MAKI	相互結線図
SCALE MASS kg	NAME DOPPLER SONAR CURRENT INDICATOR
DWG. No. G7252-C01-E	REF. No. 66-030-0001-2
INTERCONNECTION DIAGRAM	